

Electromagnetic Flow Meter

VOLUMTEC



F-TI-VOLUMTEC-B-en-13-1

Technical Information ● Manual

F-TI-VOLUMTEC-B-en-12-1/1

Table of contents

1.	General description	5
1.1.	Preface.....	5
1.2.	Structure and denomination of the device.....	5
1.3.	Function	5
2.	Safety instructions	6
2.1.	General remarks.....	6
2.1.1.	Special diligence of the user.....	6
2.1.2.	General safety instructions	6
2.2.	Intended use.....	7
2.3.	Special safety instructions and devices.....	8
2.4.	Explanation of the safety symbols used	8
3.	Transport	9
3.1.	General information.....	9
3.2.	Special notes.....	9
4.	Arrangement.....	10
4.1.	Conditions required for the transmitter.....	10
4.1.1.	Parts of air and gas	10
4.1.2.	Solid parts	10
4.1.3.	Fitting position – electrode axis	10
4.1.4.	Inlet and outlet pipe sections	12
4.1.5.	Conductivity conditions.....	12
4.1.6.	Interference fields.....	13
4.1.7.	Earthing/grounding conditions	13
4.1.8.	Meter tube lining.....	13
4.2.	Flow direction	13
4.3.	Conditions required for the converter	14
4.4.	Display turned by 90°	14
4.5.	Alignment of the converter	14
4.6.	Cable lengths for the separated version	15
4.7.	Welding work	15
4.8.	Wire end ferrule.....	15
4.9.	Cover	16
5.	Installation	17
5.1.	Installation instructions for the transmitter	17
5.2.	Installation instructions for the converter.....	17
5.2.1.	Installation of the electrical power supply	18
5.2.2.	Connection of the transmitter	20
5.2.3.	Connection scheme for the separated design.....	20
5.2.4.	Screwed EMC cable gland	21
5.3.	Electrical connection of peripherals.....	21
5.3.1.	Digital output	22
5.3.2.	Digital input	23
5.3.3.	Analog output - current output	23
5.3.4.	CS3-Bus.....	24
6.	Commissioning	25
6.1.	General information.....	25
6.2.	Advice for starting-up the VOLUMTEC.....	25
6.3.	Basic settings upon delivery.....	25

6.3.1.	System structure and operating elements	26
6.4.	Zero point adjustment (“ZERO adjust”)	26
6.5.	Metering interruption (assignment of the digital input)	26
6.6.	Metering with an empty meter tube	26
6.6.1.	Internal "EMPTY pipe detection"	26
6.7.	Use of the internal BUS interface	26
6.8.	Optical operating elements	27
7.	Operation	28
7.1.	Basic keypad functions	28
7.2.	Image navigator	29
7.2.1.	Zero reset of the volume counter.....	30
7.2.2.	How to delete malfunction messages	30
7.2.3.	Parameter change.....	30
7.2.4.	How to release a parameter change:.....	31
7.2.5.	How to release the service functions:	31
7.3.	Image level: Measured values	31
7.3.1.	Measured value: Volume.....	31
7.3.2.	Measured value: Flow rate	31
7.3.3.	Measured value: Flow rate and volume	32
7.3.4.	Measured value: Total quantity.....	32
7.3.5.	Error message: Transmitter not connected.....	32
7.4.	Image level: Base parameters	32
7.4.1.	Language	32
7.4.2.	CS3Bus address	32
7.4.3.	Dimension	33
7.4.4.	Profibus address	33
7.4.5.	Q type	33
7.5.	Image level: Pulse output	33
7.5.1.	Pulse mode	34
7.5.2.	PV1	35
7.5.3.	TP1	35
7.5.4.	PV2	35
7.5.5.	TP2	35
7.6.	Image level: Digital input	35
7.6.1.	Function: Digital input.....	36
7.6.2.	IT1.....	36
7.7.	Image level: Current output	36
7.7.1.	Current output mode	36
7.7.2.	Qmax	37
7.7.3.	TP3	37
7.8.	Image level: Metering parameters	37
7.8.1.	LFS	37
7.8.2.	MSPE	37
7.8.3.	BSPE	38
7.8.4.	Average.....	38
7.8.5.	Offset	38
7.8.6.	SPAN	38
7.8.7.	Pipe Detect (recognition of an empty meter tube).....	38
7.8.8.	Nominal width.....	39
7.9.	Image level: Special functions	39
7.9.1.	Zero adjust	39
7.9.2.	Factory setting.....	39
7.10.	Image level: Service level	39
7.10.1.	Error register: Metering.....	40
7.10.2.	Error register: Operating system.....	40

7.10.3.	Simulation of the current output.....	40
7.10.4.	Simulation of the pulse outputs.....	40
7.10.5.	Simulation of the flow rate	41
7.11.	Image level: Info.....	41
7.11.1.	Info1	41
7.11.2.	Info2.....	41
7.11.3.	Info3.....	41
8.	Parameterization	42
8.1.	Adjustments.....	43
8.1.1.	Adjustment by calibration factor "m spe"	43
8.2.	Measuring accuracy:	44
9.	Troubleshooting.....	44
9.1.	Error diagnosis	44
9.1.1.	Error diagnosis via the display.....	44
9.1.2.	Error list.....	45
9.2.	Typical effects or error sources.....	45
9.2.1.	Flow without flow rate indication:	45
9.2.2.	No pulse transmission despite displayed flow.....	46
9.2.3.	No analog signal available.....	46
9.2.4.	Deviations of measured values.....	46
9.3.	Error reset	47
9.4.	Transmitter tests.....	47
9.4.1.	Insulation test.....	47
9.4.2.	Visual check.....	47
10.	Maintenance	48
10.1.	Safety instructions for maintenance work	48
10.2.	Routine maintenance.....	48
10.2.1.	Preventive maintenance steps.....	48
10.3.	Repairs	49
10.3.1.	Sending-in the flow meter to the manufacturer	49
10.3.2.	Repair Work	49
10.3.2.1.	Replacement of the sealing cover of the operating unit	49
10.3.2.2.	Replacement of the transmitter.....	50
10.4.	Special program functions	50
10.4.1.	Flow simulation	50
10.4.2.	Simulation via the display unit	50
10.5.	Spare parts to be kept available on stock.....	50
11.	Decommissioning	50
11.1.	Temporary decommissioning	50
11.2.	Final decommissioning / disposal	50
12.	Technical Data.....	51
13.	Dimensional drawings	52
14.	Ordering information	56
15.	Contact details	57

1. General description

1.1. Preface

This documentation includes some information protected by copyright. Without prior authorization by **Hengesbach GmbH & Co. KG** this instruction manual is not allowed to be photocopied, copied, duplicated, translated, or recorded on data carriers (neither completely nor in extracts).

This instruction manual should be carefully read before the installation and operation of the device is started. It has to be deposited in the direct vicinity of the device described, easily accessible to all persons concerned.

The safety instructions have to be strictly observed.

Hengesbach GmbH & Co. KG cannot assume any liability or legal responsibility for operating errors caused by the non-observance of these directions.

1.2. Structure and denomination of the device

This instruction manual refers to both the compact all-in-one design and for the separated version of the electromagnetic flow meter.

The VOLUMTEC is available in the following versions:

- **VOLUMTEC_K_DC** operated by DC power supply, compact version
- **VOLUMTEC_K_AC** operated by AC power supply, compact version
- **VOLUMTEC_G_DC** operated by DC power supply, separated version
- **VOLUMTEC_G_AC** operated by AC power supply, separated version

Compact version:

Transmitter and converter form a whole.

Separated version:

The transmitter is installed in the pipeline. The converter is fixed to the wall by means of a wall bracket. Both component groups are connected by means of a connection cable for coil current supply and electrode signals.

This instruction manual does not deal with the weights and measures-approved versions of the flow meter.

1.3. Function

The electromagnetic flow meter, type VOLUMTEC, measures both the flow rate and the volume of liquid flows at a high precision.

The measuring device is suitable for measuring conductive liquids in principle.

The VOLUMTEC converter is microprocessor controlled. It supplies the transmitter with a switched and regulated coil current.

The signal generated at the electrodes is amplified in the converter, conditioned and shown in the internal measuring registers both as flow rate and volume information.

Volume pulses (pulses per volume unit) are output for controlling and regulating purposes.

The instantaneous flow rate is output as an analog signal of 0 or 4...20 mA according to the desired range of 0...100 %.

When leaving the factory, each device is adjusted in such a way that only the power supply and any peripherals will have to be connected.

2. Safety instructions

Due to the great variety of possible conditions of use, this instruction manual can consider the general kind of application only.

Special cases such as extraordinary ambient conditions or special safety instructions require coordination with the manufacturer.

2.1. General remarks

2.1.1. Special diligence of the user

This measuring instrument has been designed and built in consideration of a risk analysis and after a careful choice of the harmonized standards and further technical specifications to be kept. It corresponds to the state of the art and offers an optimum safety.

In practical use, however, that degree of safety can only be obtained when all measures required in this respect will be really taken. It belongs to the diligence of the user of the flow meter to plan such measures and to check and survey if they are really fulfilled.

In particular, the user has to ensure that:

- The measuring instrument is only used for the intended application as directed (also see the following chapter "Intended use").
- The measuring instrument is operated in a perfect and functioning condition and that especially the safety devices are regularly checked for their proper operation.
- The personal protective equipment required for the operating, maintenance, and repair staff is kept available and really used.
- The complete instruction manual in a legible condition is permanently available at the location of the measuring device.
- The device is operated, serviced, and repaired by sufficiently qualified and authorized personnel only.
- The personnel concerned is regularly trained for all applicable questions of the protection of labour and environment and familiarized with the instruction manual and especially the safety precautions included therein.
- All the safety and warning instructions attached to the measuring instrument are not removed and kept in a legible condition.

In case of problems that he cannot remove on his own, the user of the system should contact the service department of **Hengesbach**.

2.1.2. General safety instructions

These safety instructions have to be strictly observed in order:

- To not endanger the safety of persons and environment
- To avoid any damages to the measuring instrument
- To prevent any faulty batches upon the production

The electric connection may only be carried out by persons who have got the necessary expert knowledge (e.g. trained electrical fitters or persons instructed in electrical engineering) and the necessary authorization from the user.



**Warning of
dangerous voltage!**

**Unauthorized persons are not allowed to
open a housing that shows this symbol!**



**Important
information**

The wiring of the voltage supply and the inputs and outputs of the control circuits has to be carried out professionally in consideration of the up-to-date state of the art. Also refer to **chapter 5** "Installation"/"Electrical Connection".

In particular, the following references have to be observed:

- Safety instructions
 - Electrical connection data
1. All persons who are involved in the installation, commissioning, operation, service, and maintenance of the flow meter have to be qualified accordingly.
 2. This instruction manual has to be strictly observed. The user of the flow meter has to guarantee that the personnel concerned has read and fully understood the instruction manual.
 3. All kinds of work have to be done with utmost care and may be carried out by accordingly authorized and trained personnel only. At any rate the directives of the respective country for opening and repairing the devices have to be considered.
 4. The instruction manual has to be available close to the flow meter, easily accessible to the operating staff.
 5. Before starting any cleaning, conversion, service or maintenance work, the measuring device has to be switched off and separated from the mains supply. This requires a device for separating all live wires, e.g. a 2-pole main switch in the control cabinet. The associated device has to be protected against unauthorized switching-on.
 6. Before starting any service and maintenance work, the system has to be flushed with water and emptied. If the flow meter has to be removed from the pipe system, all pipelines will have to be previously emptied and protected by means of some appropriate emptying and shut-off measures.
 7. The flow meter fulfils the general safety requirements according to EN 61010.
 8. Never remove or put out of action any safety devices by modifications to the flow meter!
 9. Do not touch any parts flown through by the medium while the measuring instrument is cleaned. Otherwise, you run the risk of getting burnt!
 10. To minimize the danger of injury, the working area of the operator has to allow sufficiently free space.
 11. The technical data according to the instruction manual, nameplate and, if available, the performance specification has to be considered.

If damage is caused due to an inexpert performance of work any warranty claims will definitely extinguish.

Dangers not resulting from the functionality of the device, but from the ambient and operating conditions prevailing at the place of application, have to be referred to in appropriate instructions to the operators and by the attachment of some danger signs!

The user of the device is exclusively responsible for the compliance with these instructions!

2.2. Intended use

The measuring instrument is only allowed to be used for the application that it has been designed, dimensioned and built for:

- the connection to an earthed monophasic network or a direct current network (see the nameplate)
- in industrial areas according to EN 61000-6-2/4 for reasons of EMC

The intended purpose of the electromagnetic flow meter is the measurement of conductive liquids in the food processing industry and in the cosmetic, pharmaceutical and chemical industries.

This flow meter is *not* suitable for the measurement of hazardous, explosive, and combustible liquids of PED group 1.

Any modifications to the measuring device that might have an influence on the function and the safety devices of the flow meter are only allowed to be carried out by the engineering specialists or authorized persons of Hengesbach GmbH & Co. KG.

Possible misuse

Any utilisation being in contradiction to the above-mentioned application means an inadmissible misuse of the measuring instrument! In such a case Hengesbach GmbH & Co. KG does not assume any responsibility for the safety.

Hengesbach GmbH & Co. KG has to be contacted before the flow meter will be used for any different application, and after a careful investigation of all facts Hengesbach GmbH & Co. KG could possibly release the flow meter for the intended new application.











2.3. Special safety instructions and devices

The following dangers could be directly or indirectly caused by the flow meter, type VOLUMTEC, during operation or commissioning:

- Electric shock if the electronic housing is opened improperly
- Burns by touching hot pipe sections
- Scalds and/or chemical burns by hot liquids or gas coming out through leaking flange connections or because of an inexpert opening of the pipe system

2.4. Explanation of the safety symbols used

The VOLUMTEC flow meters are reliable in operation and meet the highest technical specifications. They leave our factory at a safety-related flawless condition. The devices correspond to the relevant standards and directives according to EN 61010 "Electrical safety testing for measurement and laboratory devices". However, a hazard can originate from the devices, if they are used inexpertly and not for their intended purpose. Therefore, strictly observe the safety instructions of this instruction manual which are marked by the following symbols:

 <p>Important information</p>	 <p>Hot caustic solution can cause serious chemical burns</p>	 <p>Caution</p>
 <p>Warning of dangerous voltage</p>	 <p>Warning against hand injuries</p>	 <p>Warning against hot surfaces</p>
 <p>Warning against hot liquids and steam</p>	 <p>Warning against irritating substances or media detrimental to health</p>	 <p>Warning against an increased risk of skidding in wet areas</p>
 <p>Endangered electrostatic component</p>	 <p>Electronic scrap</p>	

3. Transport

3.1. General information

The following points have to be respected in order to avoid damages to the measuring instrument or injuries during the transport of the device:



Caution

Transport work is only allowed to be carried out:

- **By accordingly qualified and authorized persons**
- **By the aid of appropriate load suspension and fastening devices**
- **If any risk can be fully excluded while the device is lifted or conveyed**

The packing of the measuring instruments is subject to the following labelling:

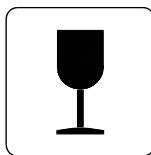

Fragile goods

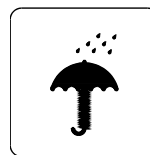

Keep dry!

Check the added packing list before you will start opening the packing!

Compare by means of the packing list if all parts are really available or not!

Treat sensitive parts with special care!

Please do not fail to dispose of the packing material according to the appropriate regulations.

3.2. Special notes

When removing the packaging film, see to it that no components of the device (such as display or keypad) are damaged or destroyed.

4. Arrangement

4.1. Conditions required for the transmitter

The installation of the measuring instrument depends on the version delivered: “**separated**” or “**compact**”.

In any case the transmitter has to be installed in the product line and the converter has to be supplied with voltage.

When selecting the place for the installation of the measuring instrument you should in any rate ensure that the housing can be opened for service work whenever desired and that the flow meter can be simply removed, if necessary.

Equalising currents between the transmitter and the converter have to be absolutely avoided, as they will cause measuring errors.



Caution

In order to protect the transmitter against damages, select the place of installation so that:

- the process pressure is always kept below the admissible operating pressure
- the product temperature is always kept below the admissible temperature
- the transmitter is mechanically levelled out (e.g. to avoid vibration)
- the meter tube can be emptied in case of the danger of frost
- the measuring instrument is not arranged straight above a gully or sink hole
- the connection housing is not permanently exposed to drip water

4.1.1. Parts of air and gas

The electromagnetic measuring instrument can supply perfect measuring results in case of gas-free liquids only. Air locks or deaeration in a liquid will lead to faulty measurements.

Thus, make sure that air locks or other possible parts of gas are safely separated before the measuring device e.g. by gas separators or that deaeration can be excluded by a sufficient working pressure.

The measuring device is not damaged e.g. by air locks.

4.1.2. Solid parts

Normally, solid parts do not have any negative influence on the volume measurement.

The pipe diameter should always be chosen sufficiently large in order to prevent the meter tube from being clogged in case of products including solid particles.

Due to the fact that the flow velocity of solid matters is relatively lower than that of the liquid part of the product, a higher flow fluctuation could be caused while the flow rate is determined.

The measurement of abrasive materials can cause a drifting of the measuring accuracies and, in the end, a deterioration of the transmitter.

4.1.3. Fitting position – electrode axis

Due to the principle described, the fitting position – to a certain extent – can be selected any way desired. The basic condition for accurate measuring results is, however, a full and gas-free meter tube.

If possible, the electrode axis should be horizontally arranged, in order to avoid a deposition of gas bubbles or solid particles on the surface of the electrodes. Therefore, a slightly ascending pipeline is advisable, preferably with a deaerating possibility at its highest position.

The fitting position should be chosen in such a way that a good readability and handling of the operating unit is guaranteed.

The pipelines within the inlet and outlet pipe sections must not show any unevenness, e.g. welding beads.

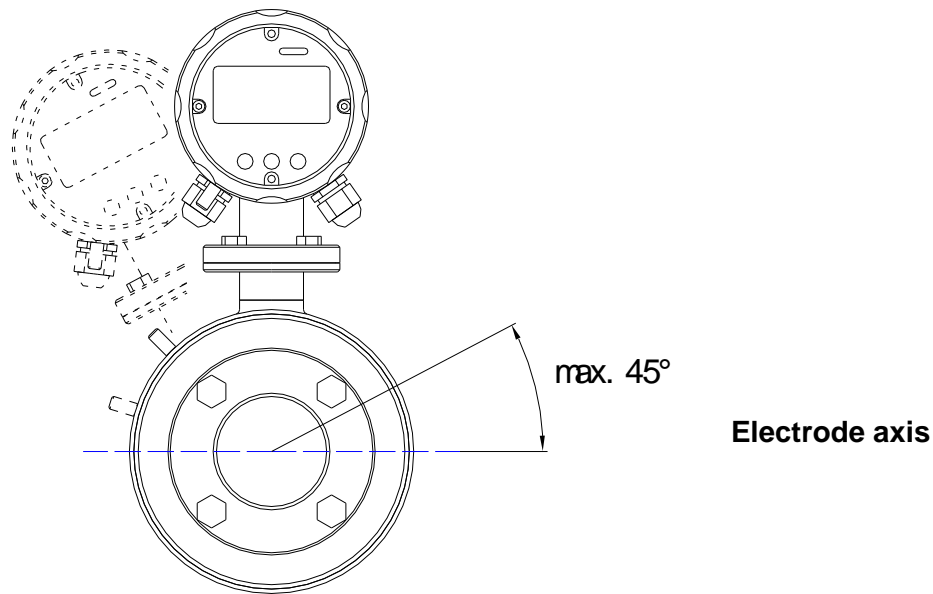

Suggestions for installation

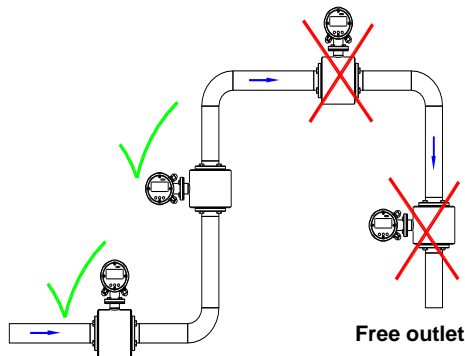

Wrong

At the highest point of the pipeline. Gas bubbles accumulate in the transmitter. → Faulty measurement!

Wrong

Descending pipe:

At the end of the conveyance of the metered product the pipe runs empty. → Measuring errors!

Correct

Preferred mounting position:

Rising pipeline and horizontal pipe section before an ascending pipeline

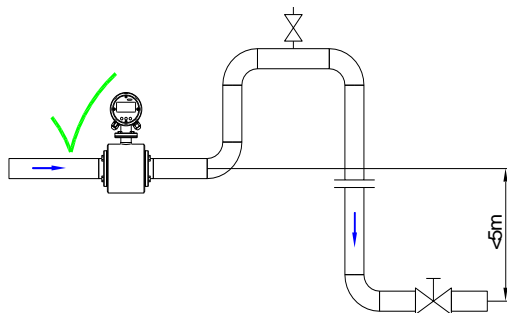

Descending pipelines of a length of more than 5 m have to be equipped with a deaeration valve after the flow meter.

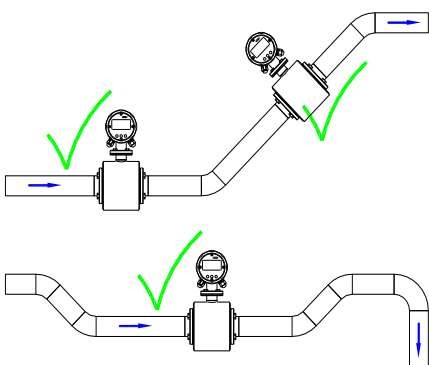

Correct

In case of a horizontal pipe conduct the mounting position is placed in slowly increasing sections of the pipe.

Correct

Provide a culvert for free inlet or outlet. The transmitter is permanently filled with liquid as demanded.

Free outlet

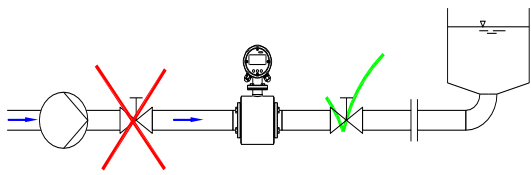

Long lines **after** the flow meter always have to be equipped with a shut-off device. If it is placed before the flow meter, a vacuum will be caused in the metering pipe by the big kinetic energy in the liquid column when shutting off. This can damage the lining of the tube!

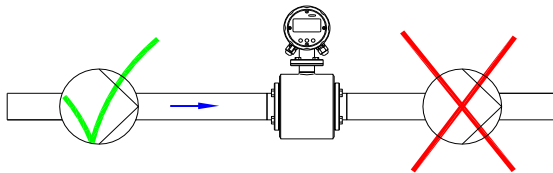

Do not place the flow meter on the suction side of the pump! → **Danger of negative pressure!**

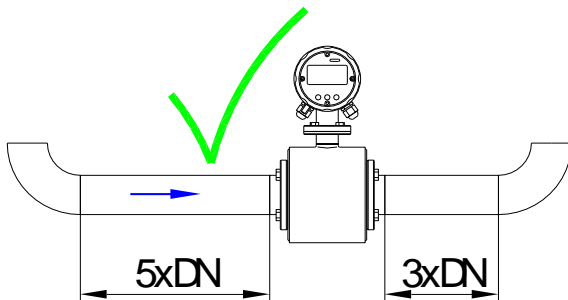

Keep the recommended inlet and outlet sections!

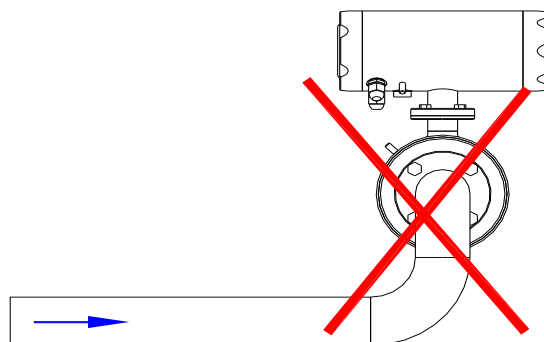

Avoid curvatures of space before the flow meter!

4.1.4. Inlet and outlet pipe sections

For the installation of electromagnetic transmitters DIN 1944 recommends an inlet pipe section of 5 x DN and, accordingly, an outlet pipe section of 3 x DN in case of an undisturbed flow. For an irregular flow (e.g. distorted rotational flow profile) the inlet and outlet pipe sections have to be extended accordingly or a rectifying device for the flow has to be installed in order to guarantee the specified measuring accuracy.

4.1.5. Conductivity conditions

Compact design

The liquid to be measured has to show a minimum conductivity of $\geq 5 \mu\text{S/cm}$.
Demineralised water requires a conductivity of $\geq 20 \mu\text{S/cm}$.

A count suppressor for empty meter tubes belongs to the standard equipment of the converter. That function will have to be switched off at conductivities below $50 \mu\text{S/cm}$.

Separated design

The liquid to be measured has to show a minimum conductivity of $\geq 15 \mu\text{S/cm}$.
Demineralised water requires a conductivity of $\geq 30 \mu\text{S/cm}$.

A count suppressor for empty meter tubes belongs to the standard equipment of the converter. That function will have to be switched off at conductivities below 50 $\mu\text{S}/\text{cm}$.

4.1.6. Interference fields

Straight at the transmitter masses of iron or strong permanent or electromagnetic fields must absolutely not exist, as they could influence the defined exciting magnetic field, thus falsifying the signal.

4.1.7. Earthing/grounding conditions

A perfect earthing/grounding of the transmitter is an essential requirement for a reliable and accurate measurement.

“Inductive measuring method” means that the metered liquid itself acts as an electric conductor, i.e. a correct and careful earthing/grounding ensures that no additional potentials will falsify the extremely low metering signal.

For that reason, the earthing/grounding resistance has to be definitely smaller than 10 Ω . The earth/ground wire used must not transfer any interference voltages, i.e. no other electric devices must be connected to that line.

If in case of a plastic pipe system no equipotential bonding is available between the inlet and outlet sides, it will be necessary to take some appropriate measures for a potential equalisation.

In case of the separated design, the earthing/grounding between transmitter and converter is achieved by means of the shielding braid of the electrode cables and the coil supply cables with the metal cable gland provided for that purpose.

As a rule, the shielding is connected on one side of the transmitter.

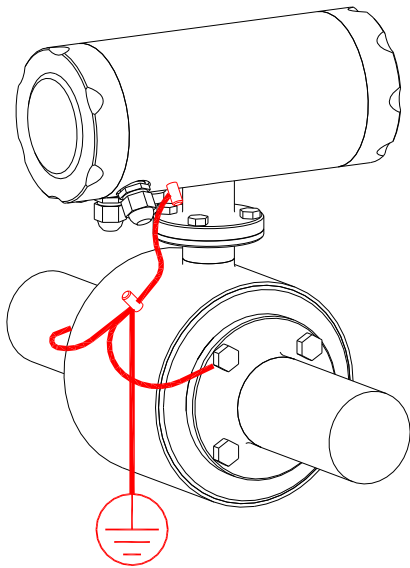

The transmitter has to be earthed/grounded as shown in this picture.

4.1.8. Meter tube lining

A damaged PFA lining can cause faulty measurements or even a failure of the flow meter.

Choose the place of installation in such a way that no negative pressure can be caused, even not when the pump is switched off. An installation at the highest point of the pipeline has to be avoided!

4.2. Flow direction

The VOLUMTEC measures the flows in both flow directions in principle. The main flow direction is marked on the converter by means of an arrow:

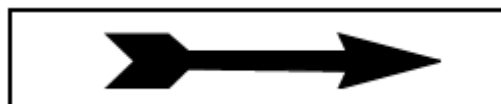

In the standard setting the digital outputs emit the volume pulses independently of the flow direction. Negative flow rates and quantities are displayed with a MINUS sign. On the condition that the inlet and outlet conditions are kept, the accuracy of the measurement in both directions is only slightly different.

4.3. Conditions required for the converter



Caution

Please observe the following points for the locating place to protect the converter against damage:

- The limit values for the ambient temperature have to be kept.
- Fasten the field housing from mechanical strain!
- No moisture may enter the field housing through the cable gland.
- The converter has to be installed at a place which is free from vibration to a large extent.
- The covers have to be closed.
- The housing may not be permanently subject to dripping water.

Apart from that, please ensure that the housing can be easily opened for service purposes. The converter has to be installed in such a way that perfect reading and operation of the operating unit is guaranteed!

4.4. Display turned by 90°

1. Remove the front cover!
2. Unscrew the 2 cylinder head screws!
3. Turn the display by +/- 90° into the desired position!
4. Screw down the 2 cylinder head screws into the same position!
5. Screw on the front cover!

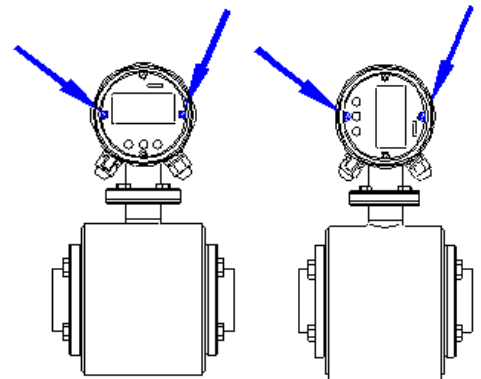

4.5. Alignment of the converter

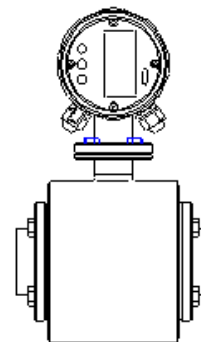
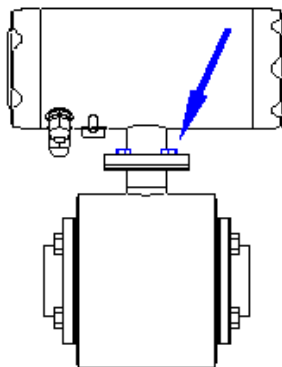

1. Loosen the 4 screws (**do not remove them!**)
2. Turn the converter into the desired direction (180° max. to the left or right)!
3. Fasten the 4 screws!

4.6. Cable lengths for the separated version

The transmitter is integrated straight into the pipeline.

For reasons of EMC, the transmitter has to be installed at a possibly small distance from the converter, i.e. the connection cable should be kept as short as possible.

The standard coil and electrode cables delivered are destined to cover a distance of 5 m each.

The following conditions have to be considered for larger distances:

- The cables have to be laid into a separate cable duct.
- Laying the cables near to frequency converters or motors has to be absolutely avoided.
- The maximum distance between transmitter and converter depends on the conductivity of the product. The following approximate values are recommended:

Conductivity	Maximum cable length
15 - 50 $\mu\text{S/cm}$	5 m
50 - 200 $\mu\text{S/cm}$	20 m
> 200 $\mu\text{S/cm}$	50 m

- The shielded cables prescribed by the manufacturer have to be used.
- For the shielding please refer to the item "Earthing/grounding conditions".

4.7. Welding work



Caution

Welding work involves the risk of destruction for the electronic measuring equipment!

Pay attention to the fact that the earthing/grounding of the welding set is not carried out through the transmitter or the converter!

The welding seams at pipelines have to be executed by means of suitable work equipment and filler materials and after a careful preparation of the pipe ends in such a way that a perfect welding effect is guaranteed and that internal stresses (e.g. welding distortion) is kept limited to the absolute minimum.

Before welding work is started, the VOLUMTEC will have to be removed from the pipeline:

- Fasten the VOLUMTEC transmitter by some welding point inside the pipeline!
- Unscrew the screws at the process connection flange! Remove the transmitter including the seal from the pipeline!
- Weld the process connection into the pipeline!
- Reinstall the transmitter into the pipeline! Pay attention to cleanliness and the correct position of the seal!

4.8. Wire end ferrule



Caution

Wire end ferrules can damage the spring clips!

Spring clips can be damaged or become useless by using too large or inexpertly wire end ferrules. Therefore, wire the VOLUMTEC without using wire end ferrules!

4.9. Cover

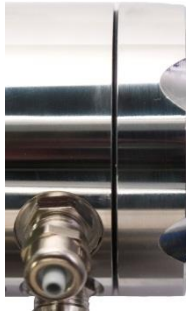

If the cover is not closed,
the flow meter will not be protected from moisture!

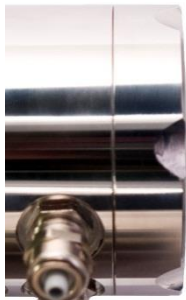

If the cover is closed (finger-tight),
the flow meter will be protected from moisture!

The VOLUMTEC is only protected from moisture, if the covers are expertly screwed down. A properly screwed down cover is recognized by the fact that the metallic stop is reached.

5. Installation

Only persons disposing of the necessary expert knowledge and authorization of the user are allowed to carry out the installation work. The qualified personnel have to have read and fully understood this instruction manual and follow all instructions given therein.

The state of the art is always a decisive criterion for the execution of the installation.

The following points should be taken into account after completion of the installation work:

- It has to be checked whether all external supply connections really meet the requirements specified in the technical data of the flow meter (e.g. pressure, temperature, etc.).
- The pipelines have to be flushed before the production is started.
- All external supply joints have to be checked for their safe, leakproof, and nearly stress-free connection to the transmitter.
- The media supplied have to be cautiously adjusted to their required working pressure.
- Occurring leaks have to be removed immediately.
- All electrical lines have to be separated from the flow meter before welding work is started at the pipeline.

The electric wiring of the voltage supply and the inputs and outputs of the control circuits has to be carried out according to the wiring diagram.

In this respect the state of the art is relevant, too.

5.1. Installation instructions for the transmitter



Caution

Pay attention to the fact that the threaded fittings, clamps, or flanges are perfectly tightened! Otherwise, hot or caustic solutions or gasses could come out of the gaps and clearances.

- Outcoming liquids can lead to slip hazard.
- Outcoming liquids have to be mopped up immediately and disposed of safely.
- If combustible liquids come out, they could cause an explosion hazardous area around that place which has to be marked accordingly.

If the transmitter is connected to existing process lines, those lines have to be unpressurized and free from product.

Do not omit to insert the seals into the screwed counterfittings!

In case of leaking pipe connections you should in any rate check the seals. Never squeeze the seal when tightening the threaded pipe connections!

5.2. Installation instructions for the converter

In case of the compact design, the converter is arranged on the transmitter, i.e. it is located straight inside the pipeline.

For the separated design the field housing is typically delivered for wall mounting.

Cable glands always have to point downwards.

When installing the flow meter, pay special attention to the fact that no moisture by drip or splash water can get onto the electronic board.

Metal particles, such as scobs or residues of the shielding braid, have to be removed from the boards before the electric power supply is switched on.

See to it that the pipelines are supported in such a way that no forces and moments are exerted on the measuring device.



Caution

The display must not be exposed to direct insolation!

5.2.1. Installation of the electrical power supply



Caution

The following safety precautions have to be followed for the execution of the electrical installation work:

Intended use

The flow meter, type VOLUMTEC, is exclusively destined for:

- The connection to an earthed/grounded monophase network
- The use in industrial areas for reason of EMC (according to definition EN 50 081-2)

Apart from that:

- The supplying system has to guarantee an overvoltage protection for the device according to category II.
- The connection cables have to be secured by a cable strap (AC version) as shown in the photograph on the next page.



Staff qualification

Necessary work to the flow meter, type VOLUMTEC, is only allowed to be performed by trained and qualified personnel in consideration of the relevant regulations for occupational safety. The flow meter has to be correctly connected according to the electrical wiring diagrams.



The nameplate of the flow meter has to be considered for the electrical connection. It is most important that the nominal voltage and the kind of voltage (AC or DC) are equal to those of the flow meter.

Important information

The electrical power supply is connected to terminal X1:

Connection of the AC power supply:

L line to X1 / L
N line to X1 / N

Protective conductor to X1 / PE
Connection cable: ÖPVC-JZ



3G0.75mm², minimum external diameter: 5.7mm

The terminal board is marked by additional AC stickers.

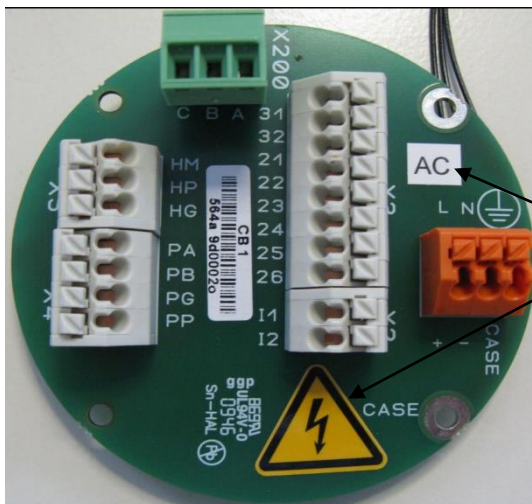

Indicating labels for the AC version

Connection of the DC power supply:

Positive cable (plus) to X1 / +
 Negative cable (minus) to X1 / -
 Protective conductor to X1 / Case

In case of the DC version the protective conductor has to be connected, too.

Connection cable: ÖPVC-JZ 3G0.75mm², Minimum external diameter: 5.7mm

The terminal board is marked by an additional DC sticker.

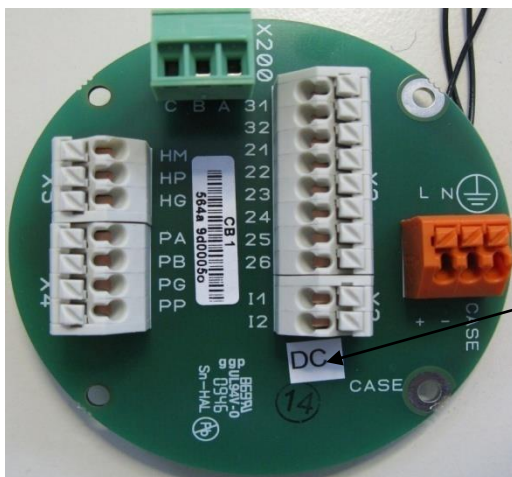

Indicating label for the DC version

The shielding braid has to be correctly connected to the cable gland in order to guarantee an optimum operation of the device according to the EMC directives.



Caution

In case of hard-wired devices without any mains switch it is **absolutely necessary to install a 2-pole switch** or a power switch in the structure of the building. That switch has to be fixed in the direct vicinity of the device, easily accessible to the user and clearly marked as a disconnecting or isolating switch for the device.

The measuring instrument can be supplied by different voltages. The supply voltage is shown on the nameplate, too.

5.2.2. Connection of the transmitter



Caution

The coil cable and the electrode cable for the separated version have to be installed after the transmitter has been built into the pipeline and after the converter housing has been fixed.

The electrical connection of transmitter and converter has to be completed before the measuring device is switched on!

You should in any rate see to it that:

- The supply voltage in the converter is switched off while the transmitter is installed.
- No moisture can drip onto the electronic unit.
- No metal particles, e.g. of the shielding braid, can fall into the electronic unit.

Function:

The magnet coils of the transmitter are supplied straight from the converter.

The ground/earth signal and the two electrode signals E1 and E2 of the converter are led to the converter.

The following cable types have to be used:

Coil cable: 2 x 0.5 mm² F-CY-OZ (simply shielded)
Electrode cable: 4 x 0.5 mm² LIYCY-0 (simply shielded)

5.2.3. Connection scheme for the separated design

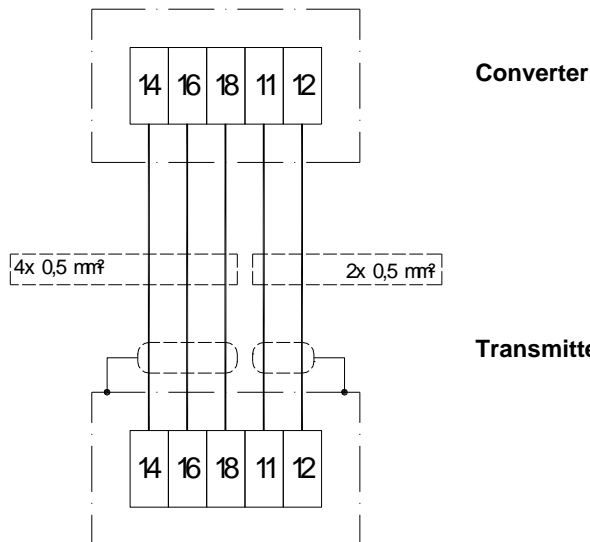

Pin assignment	
Terminal X1 / No. 11	Coil
Terminal X1 / No. 12	Coil
Terminal X1 / No. 14	Electrode 1
Terminal X1 / No. 16	Electrode 2
Terminal X1 / No. 18	GND

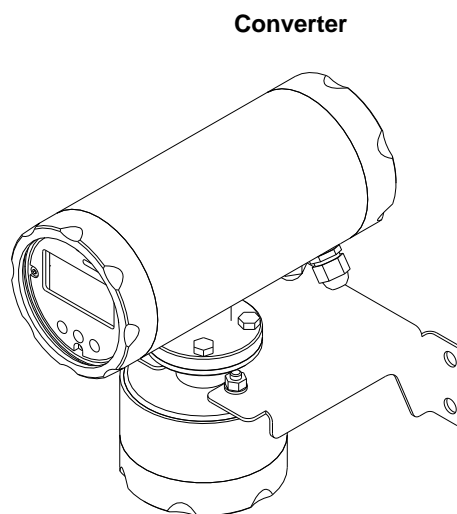
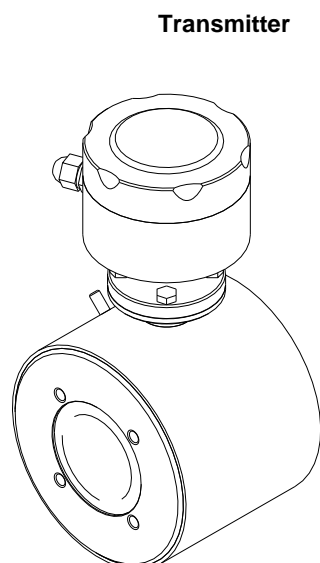

5.2.4. Screwed EMC cable gland

Figure 1: Assembly of the screwed EMC cable gland, connection of the shielding

The shielding braid of the coil and electrode cables has in any rate to be connected to the screwed

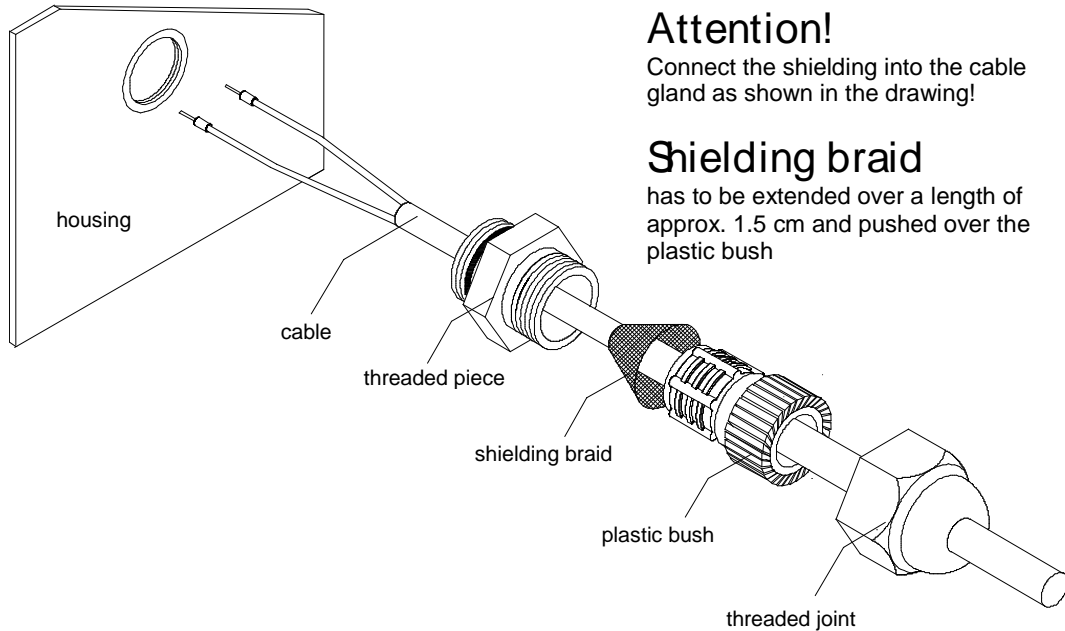

Attention!

Connect the shielding into the cable gland as shown in the drawing!

Shielding braid

has to be extended over a length of approx. 1.5 cm and pushed over the plastic bush

EMC cable glands:



Important information

The original cable glands are neither allowed to be removed nor modified. Otherwise, the warranty and the CE approval will definitely extinguish.

5.3. Electrical connection of peripherals

The following signal outputs are available:

- 3 x digital outputs, configurable for volume pulses and status output
- 1 x digital input, configurable for measuring interruption or setting to zero
- 1 x analog current output for the flow rate, configurable for:
0...20 mA/active, 4...20 mA/active, and 4...20 mA/passive
- 1 x CS3BUS interface (RS485 interface with Hengesbach CS3-Bus protocol)

The measured values of the VOLUMTEC are usually put out as volume pulses (pulses per litre) through a digital pulse output:

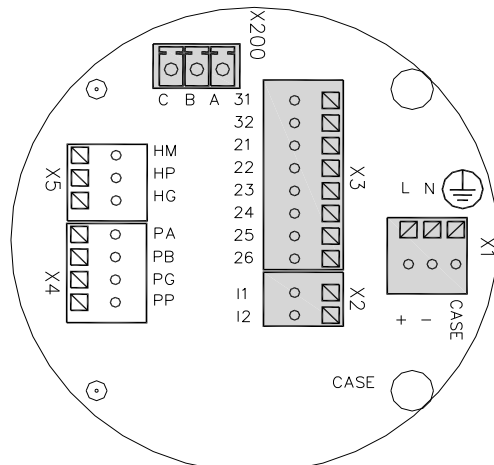

- X200 → CS3BUS, data communication
- X2 → Analog output / current output
- X3 → Digital outputs and digital input
- X1 → Connection of the power supply

5.3.1. Digital output

Digital output	
Hardware	Optocoupler, passive
Auxiliary voltage	32 V max.
Output current	20 mA max.
Voltage drop at the optocoupler at 20 mA	0.5...1 V
Output frequency	1kHz max.

The following figure shows the basic wiring diagram of the pulse outputs. The outputs switch off in case of overload. By removal of the overload the outputs will be reactivated after a few seconds.

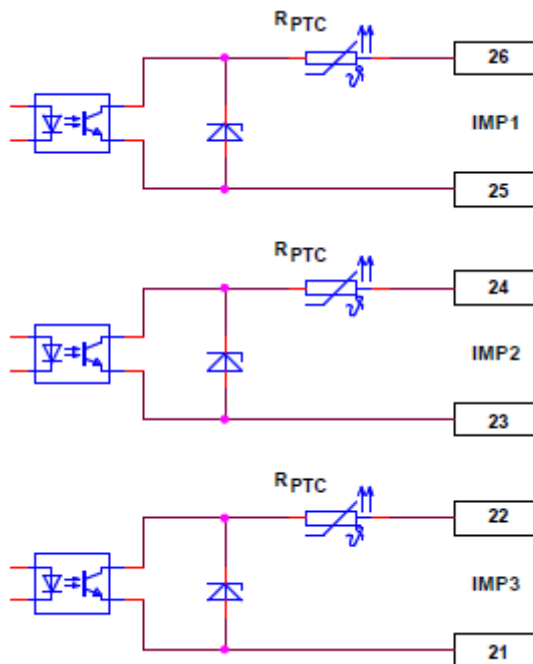
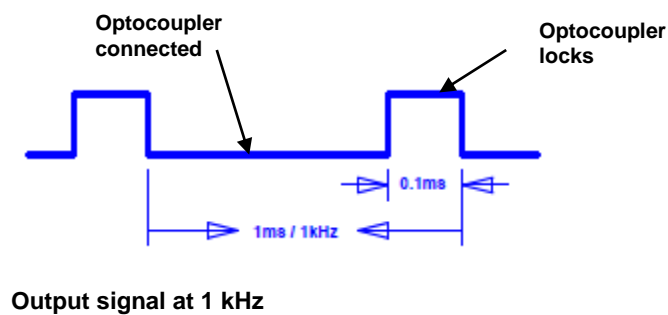

Figure 2: Pin assignment of the pulse outputs



The pulse duty cycle depends on the load, too. An electronic counter has to have an input frequency of at least 5 kHz.

5.3.2. Digital input

Digital input	
Hardware	Optocoupler, passive
Auxiliary voltage	9...32 V
Input resistance	< 3.2 k Ω
Input frequency	1kHz max.
Function	Voltage ON \rightarrow Function active
Terminal X3 / No. 32	Plus
Terminal X3 / No. 31	Minus

The following figure shows the basic wiring diagram of the control input:

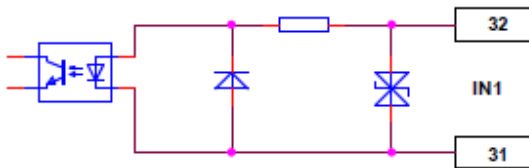

Figure 3: Pin assignment of the digital input

5.3.3. Analog output - current output

Analog output	
Hardware mode	Active or passive
Operating mode	4...20 mA / 0...20 mA
Load	500 Ω max.
Error	< 0.2 %

The analog output works in both flow directions!

**Analog output,
active current output**

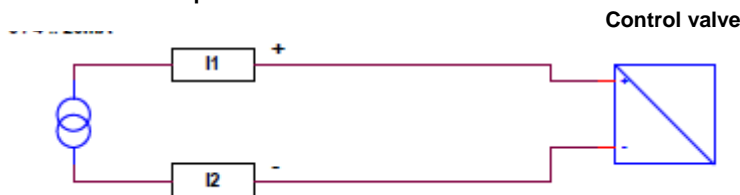

Figure 4: Pin assignment of the active current output

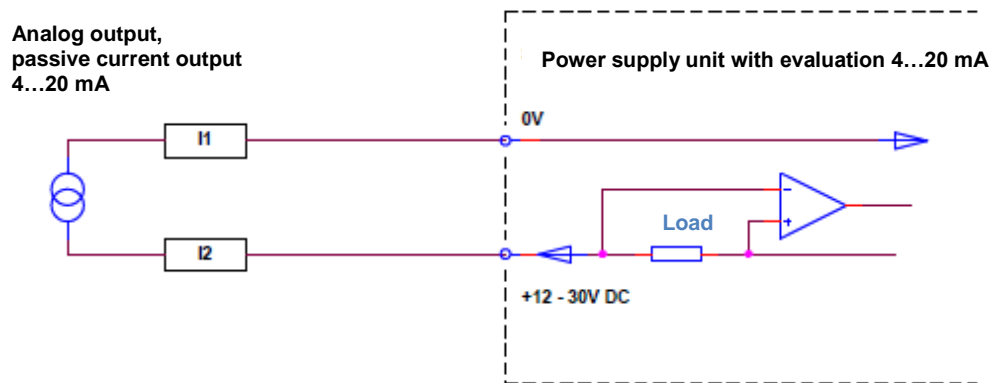

Figure 5: Pin assignment of the passive current output

5.3.4. CS3-Bus

CS3-Bus	
Hardware interface	RS485
Bus protocol	Hengesbach CS3-Bus protocol
Baud rate	57600 Bauds
X200 / A	Signal A
X200 / B	Signal B
X200 / C	GND
Cable length	100 m max.
Cable	LIYCY-0; 4 x 0.5 mm ² , shielded

The BUS is connected by a 3-pole plug-in terminal with the signals "A-B-C".

Further BUS connections are always made 1 to 1, i.e. A is connected to A, B to B, and C to C.

A BUS interface is available for a data communication. It can be used for the connection of the VOLUMTEC to some other Hengesbach devices or a PC with the IVON service program.

6. Commissioning

6.1. General information

The measuring device may only be operated by trained persons who have got the necessary authorization from the user of the device. The operators have to be familiar with the process sequence, able to recognize possible dangers, and in a position to take the necessary steps for the removal of accident risks.

Safety measures for the commissioning work



Caution

Both an orderly performed installation and a correct electrical connection are absolute prerequisites for the commissioning work!

Pay attention to the following points upon the initial start-up of the flow meter:

- Close the housings of transmitter and converter!
 - Personal injury by electric shock can be caused, if the electric lines are touched.
 - Instrument damage can be caused by moisture or metal parts on the electronic unit.
- Ensure that all threaded joints at the measuring instrument and in the direct vicinity are really tight!
- Any possibly existing dehydrating agents have to be removed from the housings before the commissioning is started!

6.2. Advice for starting-up the VOLUMTEC

1. First of all the measuring device has to be installed into the pipeline!

- The auxiliary energy has to be switched off.
- The auxiliary energy has to correspond to the specification on the nameplate.
- The pin assignment has to correspond to the wiring diagram.
- The temperature limits have to be kept.
- Both the transmitter and the converter have to be correctly earthed/grounded.
- The converter has to be installed at a place which is free from vibration to a large extent.
- The housing covers have to be closed before the auxiliary energy is switched on.
- The flow range adjusts itself automatically.
- After the electrical start-up a “ZERO adjust” should be carried out by means of the typical liquid to be measured (full meter tube and no flow!).

2. How to put into operation the analog output?

- The output can be parameterized for the application to be fulfilled and it can be operated actively or passively. The current range can be adjusted to 4...20 mA or 0...20 mA. Factory setting: 4...20 mA.
- Dependent on the flow rate, the analog output produces a current of 0/4...20 mA.
- The allocation of the flow range “20mA = Q_{max}” for the analog output of the VOLUMTEC is set by the respective parameters.
- The flow simulation can be used for a functional check.

3. Which other conditions should be taken into consideration?

- Too low product conductivity?
At less than 50 µS/cm, the internal empty-pipe detection has to be switched off by the respective parameter setting.
- Is the analog output too unsteady?
A time constant can be set by the relevant parameters.

6.3. Basic settings upon delivery

At the factory the electromagnetic flow meter is adjusted and delivered with a standard parameter setting.

6.3.1. System structure and operating elements

The electronic part is permanently installed in the VOLUMTEC converter. The display is arranged on the front above the three optical keys. The electrical connections are on the rear side of the device. The status of the device can be read on the display.

6.4. Zero point adjustment (“ZERO adjust”)

Upon the first start-up of the flow meter it is recommendable to carry out a **zero point adjustment (“ZERO adjust”)** for an adaptation of the flow meter to the conditions prevailing in situ. Normally, such an adaptation is not required for the compact flow meter version.

ATTENTION! The following conditions have to be observed for a “ZERO adjust”:

- (1) The device has to have reached its working temperature, i.e. it should have been switched on at least 5 minutes before.
- (2) The cables between transmitter and converter have to be firmly laid in consideration of the EMC rules.
- (3) The transmitter has to be clearly filled with the typical liquid free of gas.
- (4) **No flow** is allowed to be available. The liquid has to be resting.
- (5) **No flow** is allowed to occur during the whole “ZERO adjust” measurement.

6.5. Metering interruption (assignment of the digital input)

For the external interruption of the measurement, e.g. during cleaning, a digital signal can be connected to input **IN1** on the terminal board.

The input is activated by a DC voltage between 9 V and 32 V DC at terminal **X3** with PLUS to **no. 32** and MINUS to **no. 31**.

This function has to be switched on by the parameter settings.

6.6. Metering with an empty meter tube

Metrologically perfect flow measurements are only possible, if the meter tube is evidently filled with liquid. In order to avoid an undefined counting in case of an empty meter tube, the VOLUMTEC offers both an **internal** and an **external** possibility for suppression:

6.6.1. Internal "EMPTY pipe detection"

The VOLUMTEC is equipped with a special “EMPTY pipe detection” (“**pipe detect**”). The setting is made via the parameters. Usually, the EMPTY pipe detection is switched on, i.e. an undefined count will be suppressed in case of an empty meter tube.

At the following situations, the internal EMPTY pipe detection has to be switched off by the parameter setting:

- At a product conductivity of less than 50µS/cm.
- At a heavily pulsating flow (piston, membrane or hose pumps).

6.7. Use of the internal BUS interface

Via the BUS interface it is possible to connect the intelligent Hengesbach CS3 systems to the VOLUMTEC.

By means of a ZEVODAT-F (see technical data sheet D18.18E) e.g. it is possible to obtain a central remote indication of several VOLUMTEC-type flow meters.

For this purpose, it is necessary to adjust the address of the individual BUS participators by the parameters.

6.8. Optical operating elements

The display unit is provided with optical keys for the operation which enable the VOLUMTEC to be operated through the closed covers.



**Important
information**

The converter calibrates the optical keys in regular intervals. Such a calibration can only function perfectly, if the optical keys are not covered. After removal or reassembly of the covers the optical keys are not allowed to be touched for approx. 20 seconds. After that time the optical keys will be functioning again.

During the operation or during an input the calibration will be ineffective.



Caution

The operation is only permitted to be carried out while the front cover is closed. Otherwise, the operating unit, the display, and the optical keys could be damaged. Dirty fingers (e.g. by oils or fats) can cause faulty functions of the optical keys.

7. Operation

Only persons disposing of the necessary expert knowledge and authorization of the user are allowed to operate the VOLUMTEC.

During normal measurements the operation is restricted to the zero reset of the volume registers. The keypad is dynamically controlled by the image navigator.

The operating unit can be adapted to the fitting position of the flow meter in steps of 90°, thus enabling a perfect reading and handling of the operating unit.

The display is illuminated by a permanently switched on background lighting which permits a stressfree reading.

The function of the calibration switch is not described in this instruction manual.

Elements of the operating unit:

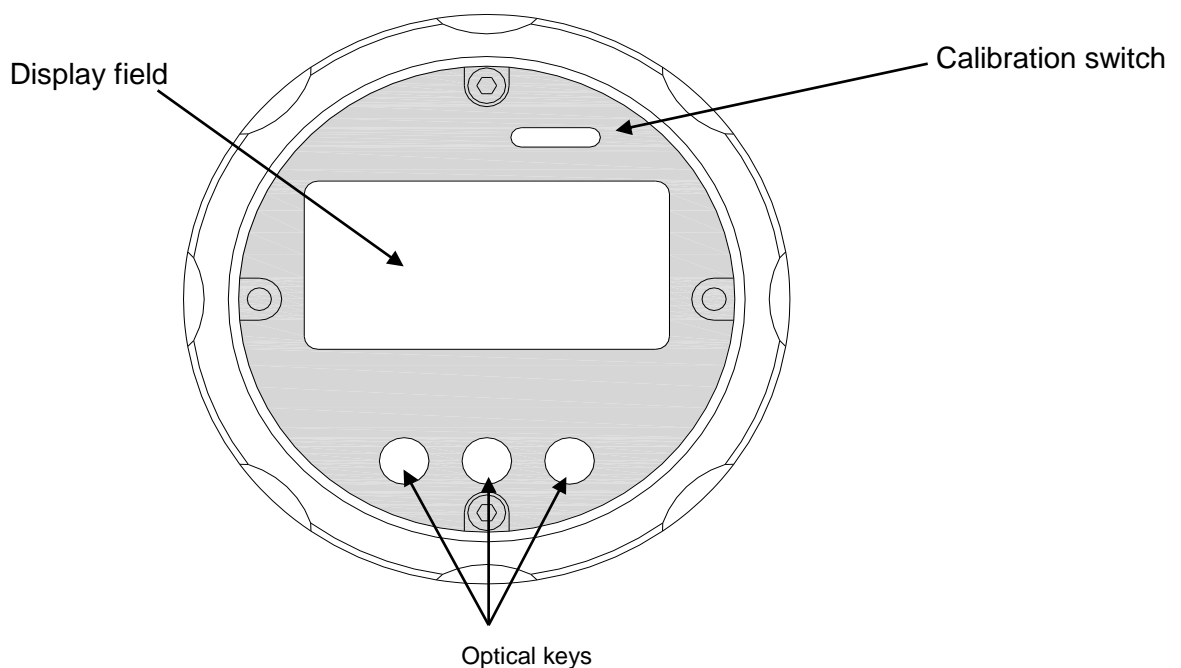

7.1. Basic keypad functions

The keypad consists of 3 optical keys. The functions of the keys are indicated by symbols and texts. The function of the keypad is dynamically controlled by the image navigator:

▲▲▲▲▲▲	To change the main image level
HOME	To return to the main image level or to the measuring image
>>>>	To change to the next sub-image
ZERO	To reset the volume to zero
++	To change the setting parameters, e.g. to change the pulse mode
Change	To change the numerical parameters, e.g. low flow quantity
<u>Key functions for the value input (numerical parameter):</u>	
<<<	Next input position
++	Changes the input position
←	ENTER, terminates the numeric input

7.2. Image navigator

The display is divided into **main images** and **sub-images**. Sub-images are allocated to each main image level.

To permit a quick overview of the parameterization the main image shows the most important parameters and settings for the adjustment of the device.

The basic setting of the image navigator is the measured value level where the volume and the flow rate are displayed. A timeout function makes sure that the VOLUMTEC always returns to that image level.

The image navigator is controlled by the keys **AAAAAA**, **>>>>** and **HOME**.

Basic functions of the image navigator:

- Reading the measured values
- Selecting the different functions
- Parameterization
- Service display

BE1 Measured value Volume	BE1 S1 Measured value Flow rate	BE1 S2 Flow rate Volume	BE1 S3 Total volume		
BE2 Base parameters Device settings	BE2 S1 Language	BE2 S2 CS3-Bus	BE2 S3 Dimension	BE2 S4 Profibus- address	BE2 S5 Q typ
BE3 Pulse output Device settings	BE3 S1 Pulse mode	BE3 S2 PV1	BE3 S3 TP1	BE3 S4 PV2	BE3 S5 TP2
BE4 Digital input Device settings	BE4 S1 Function	BE4 S2 IT-1			
BE5 Current output Device settings	BE5 S1 Mode	BE5 S2 Qmax	BE5 S3 TP3		
BE6 Meter parameters Device settings	BE6 S1 LFS	BE6 S2 MSPE	BE6 S3 BSPE	BE6 S4 Average	BE6 S5 Pipe Detect
	BE6 S6 Nominal width	BE6 S7 Offset	BE6 S8 SPAN		
BE7 Special functions	BE7 S1 Zero-Adjust	BE7 S2 Factory setting			
BE8 Service level	BE8 S1 Error-register Meter software	BE8 S2 Error-register Operatingsystem	BE8 S3 Simulation Current output	BE8 S4 Simulation Pulse output	BE8 S5 Simulation Flow rate
BE9 Info1	BE9 S1 Info2	BE9 S2 Info3			

7.2.1. Zero reset of the volume counter

The main image shows the volume. This image is permanently shown while the flow meter is switched on. "Zero reset" is a function which can be carried out without any additional activation. For a zero reset, please keep the **ZERO** key depressed for about 5 seconds.



7.2.2. How to delete malfunction messages

Possible malfunction messages are deleted by resetting the volume counters.

7.2.3. Parameter change

There are two kinds of parameters, in principle:

- **Setting parameters**, e.g. pulse mode
- **Numerical parameters**, e.g. TP1

A setting parameter is changed by the **++** key. The **change** key opens an input field for the entry of the numerical parameter selected.

A parameter change is only possible, if it has been unlocked before. Unless it is unlocked, the input of the unlock code is requested automatically.

How to change a numerical parameter:

Press the **change** key and an input field will appear. The instantaneous value is shown inversely, whereas the changeable position is normally shown.

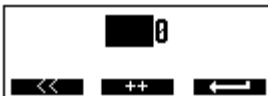

The **++** key changes the digit in the input position. The next left-hand input position is selected by the **<<** key. If the numerical parameter is set to the desired value, the input is terminated and accepted by the **←** key.

How to change a setting parameter:

The procedure is described by means of the example of the "pulse mode".

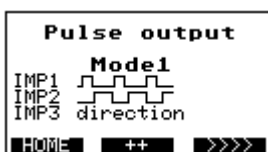

The current pulse output mode is set to "Mode 1". The next mode is selected and/or adjusted by means of the **++** key.

The next pulse output mode appears on the display.

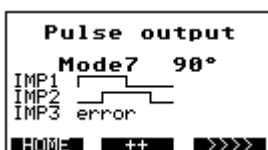

7.2.4. How to release a parameter change:

If a parameter has to be changed and the parameter change is not released, the display will request the input of the code number.



Input the code number as described in item 7.2.3. If the correct code number has been input, the display will show the message "Parameter input unlocked". In case of a wrong code number the display will show "parameter input blocked".

Code number for the parameter change: **222**.

7.2.5. How to release the service functions:

Some service functions have to be released by a code number. Unless they are released, the display will show a request to input the code number.



Input the code number as described in item 7.2.3. If the correct code number has been input, the display will show the message "Service level unlocked". In case of a wrong code number the display will show "Service level blocked".

Code number for the service level: **333**.

7.3. Image level: Measured values

The image level consists of the pictures BE1, BE1S1, BE1S2, BE1S3.

7.3.1. Measured value: Volume



A 4-seconds long activation of the **ZERU** key will reset the volume to "0".

The size of the digits is controlled by the size of the measured value.

The volume indication is the central image that is always shown after a reset.

The volume will be reset automatically, if the value exceeds 1.000.000.000 or falls below -100.000.000.

7.3.2. Measured value: Flow rate



The size of the digits depends on the size of the measured value.

7.3.3. Measured value: Flow rate and volume

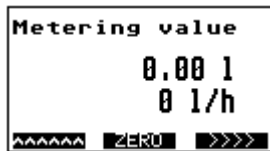

Joint indication of volume and flow rate
 The volume will be reset automatically, if the value exceeds 1.000.000.000 or falls below -100.000.000.

7.3.4. Measured value: Total quantity



The totalizer indicates the total sum of the quantities passed through the flow meter.
 The totalizer cannot be reset to zero.

7.3.5. Error message: Transmitter not connected



This error message will be displayed, if the transmitter is not connected. This error can normally occur in case of the separated design only. The cause of the error is the missing coil connection.

7.4. Image level: Base parameters

The image level consists of the following pictures: BE2, BE2S1, BE2S2, BE2S3, BE2S4 and BE2S5.



This image level offers the possibility to make some basic settings. The main image shows the current device setting.

7.4.1. Language



Use the key **++** for changing the language.
 You might be prompted to first input an unlock code.

7.4.2. CS3Bus address



The CS3-Bus address can be changed by means of the key **++**.
 You might be prompted to first input an unlock code.

7.4.3. Dimension



The **++** key can be used for changing the dimension (unit) of the measured value. You might be prompted to first input an unlock code.

Abbreviation	Unit	m dim
l	Litres	1
m ³	Cubic metres	0.001
hl	Hectolitres	0.01
ml	Millilitres	1000
gal	U.S. gallons	0.2642
gal	Gallons (CDN)	0.21997
gal	Imp. Gallons	0.21997
lb	lb raw milk	2.27189
bbl	beer barrels	0.00611
dm ³	Cubic decimetres	1

7.4.4. Profibus address

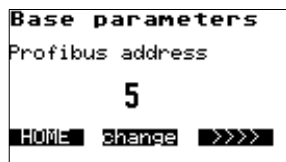

The Profibus address can be adjusted by means of the key **ändern**. Possibly the input of the unlock code is requested before.

7.4.5. Q type



The key **++** can be used for setting the unit of measure for the flow rate indication. Possibly the input of the unlock code is requested before. Two different settings are possible: l/h or l/min.

7.5. Image level: Pulse output

The image level consists of the pictures: BE3, BE3S1, BE3S2, BE3S3, BE3S4, and BE3S5.



This image level serves for the setting of the pulse output. The main image shows the current device setting.

7.5.1. Pulse mode

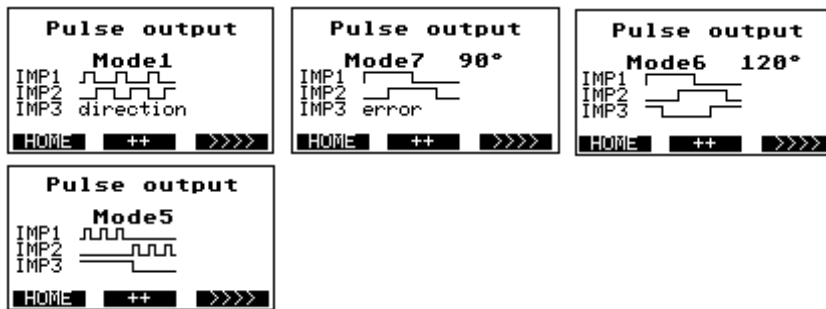

The pulse mode can be changed by means of key **++**.
You might be prompted to first input an unlock code.

- Mode21** 2 independent channels (IMP1 and IMP2) with different values (pv1 and pv2)
Pulse output independent of the flow direction.
Maximum pulse length of tp1 and tp2 in ms
0 ms = pulse-to-pause ratio 1:1.
Maximum frequency: 1000 Hz.
IMP3 determines the direction. Positive flow direction: IMP3 is connected.
- Mode25** IMP1 outputs the positive quantity pulses. Pulse value: PV1.
IMP2 outputs the negative quantity pulses. Pulse value: PV2.
Maximum frequency: 1000 Hz
IMP3 determines the flow direction. The output is connected at the positive flow direction.
- Mode6** 3-channel, shifted by 120°: IMP1, IMP2 and IMP3.
Pulse value: pv1.
Pulse-to-pause ratio: 1:1
Maximum frequency: 333 Hz
In the event of an error IMP2 is switched off.
- Mode27** 2-channel, shifted by 90°: IMP1 and IMP2. Pulse value pv1.
Pulse-to-pause ratio: 1:1.
Maximum frequency: 500 Hz.
In the event of an error IMP3 is connected.

7.5.2. PV1

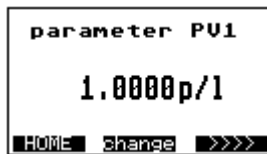

The pulse value PV1 can be changed by the **change** key. PV1 is valid for Mode1, Mode7 and Mode6. You might be prompted to first input an unlock code.

7.5.3. TP1



Use the key **change** to change the pulse length of TP1 to ms. TP1 is valid for Mode1 only. The value of 0 ms sets the pulse-to-pause ratio to 1:1. You might be prompted to first input an unlock code.

7.5.4. PV2

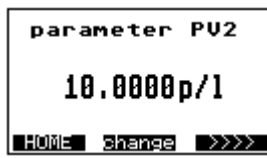

The key **change** can be used to change the pulse value PV2 for the output IMP2. PV2 is valid for Mode1. You might be prompted to first input an unlock code.

7.5.5. TP2



By means of the key **change** the pulse length of TP2 in ms can be changed for output IMP2. TP1 is valid for Mode1 only. The value of 0 ms is used to set the pulse-to-pause ratio to 1:1. You might be prompted to first input an unlock code.

7.6. Image level: Digital input

This image level consists of the pictures BE4, BE4S1, BE4S2.

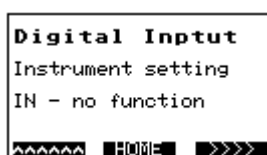

The settings for the digital input are made on this image level. The main image shows the current device setting.

7.6.1. Function: Digital input

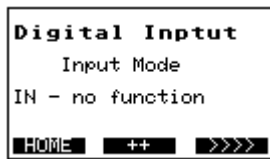

The function of the digital input can be selected by means of key **++**.

The input can be set to:

- No function
- Count interruption
- Zero setting

The key **++** only appears if the unlock code has been activated before.

You might be prompted to first input an unlock code.

7.6.2. IT1



The **change** key can be used to change IT1 to ms. IT1 determines how long the signal will have to be available for the input to permit the selected function to become active.

You might be prompted to first input an unlock code.

7.7. Image level: Current output

This image level consists of the pictures BE5, BE5S1, BE5S2, and BE5S3.



On this image level the settings for the current output are made.

The main image shows the current setting of the device.

7.7.1. Current output mode



By this key **++** you can change the mode for the current output.

You can choose among 3 different modes:

- 4 – 20 mA active
- 4 – 20 mA passive
- 0 – 20 mA active

Active / passive - see analog output.

You might be prompted to first input an unlock code.

7.7.2. Qmax



The key **change** can be activated for changing the Qmax value for the current output. Qmax is the value for 20 mA. You might be prompted to first input an unlock code.

7.7.3. TP3

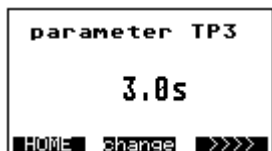

By means of the key **change** you can change the time delay TP3. The current output is attenuated by this time. You might be prompted to first input an unlock code.

7.8. Image level: Metering parameters

The image level consists of the following pictures: BE6, BE6S1, BE6S2, BE6S3, BE6S4, and BE6S5.



The settings for the measurement are made on this image level. The main image partially shows the current device settings.

7.8.1. LFS

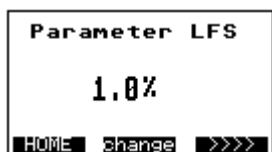

The key **change** can be used to change the low-flow suppression LFS in %. The low-flow volume is calculated from the Qmax value. You might be prompted to first input an unlock code.

7.8.2. MSPE

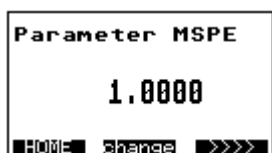

By means of the key **change** you can change the dimensionless factor MSPE. You might be prompted to first input an unlock code.

7.8.3. BSPE

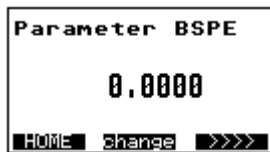

Use the key **change** for changing the dimensionless offset BSPE. You might be prompted to first input an unlock code.

7.8.4. Average



The average value can be changed by means of the key **change**. You might be prompted to first input an unlock code.

7.8.5. Offset

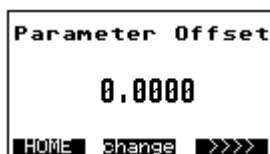

Press the key **change** for changing the Offset value. **The Offset is a calibration value of the sensor which is normally not changed!** You might be prompted to first input an unlock code.

7.8.6. SPAN

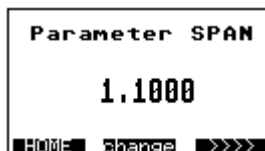

The SPAN value can be changed by the aid of the **change** key. **The SPAN value is a calibration value of the sensor which is normally not changed!** You might be prompted to first input an unlock code.

7.8.7. Pipe Detect (recognition of an empty meter tube)



The empty pipe detection can be switched on and off by means of the **++** key. You might be prompted to first input an unlock code.

7.8.8. Nominal width

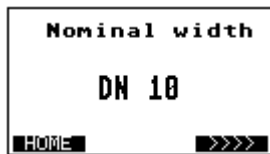

The display shows the nominal width of the transmitter.

7.9. Image level: Special functions

This image level consists of the pictures BE7, BE7S1, BE7S2.



Special functions can be carried out on this image level.

7.9.1. Zero adjust



The "ZERO adjust" measurement is activated if the **ADJ** key is depressed for a period of 1.5 seconds. The top line of the display shows the current ZERO value. The course of the bargraph shows the progress of the measurement. The measurement is finished when the bargraph is completely filled. The new ZERO value is displayed below the bargraph and taken over.



Prerequisite:

The meter tube has to be filled up with the liquid to be measured.

No flow rate is allowed to be available, the liquid rests.

Unless the prerequisites are observed, a faulty ZERO value will be determined and the VOLUMTEC will not be able work correctly.

Important information

7.9.2. Factory setting



All parameters are reset to the factory setting. After the execution of the function, the image navigator will change back to the image of item 7.9.

You might be prompted to first input an unlock code.

7.10. Image level: Service level

The image level consists of the pictures BE8, BE8S1, BE8S2, BE8S3, and BE8S4, BE8S5.



Only service values are displayed and service functions are performed on this service level.

7.10.1. Error register: Metering

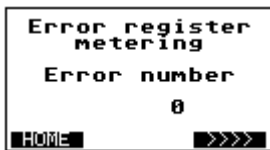

This image shows the error numbers of the measurement.
 The error number is reset while the flow meter is set back to zero.

7.10.2. Error register: Operating system

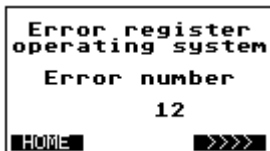

This image shows the error numbers of the operating system.

7.10.3. Simulation of the current output



The simulation can be used to check the cable connection or to adjust an analog instrument.
 The first value 20 mA is set to 100 % by means of the key **++**. Another activation of the key **++** will set 12 mA, 50 %. After that the key **++** is used for the setting of the value of 4 mA to 0 %. The simulated current value is determined by the current mode, see item 7.7.1. If the setting is 0...20 mA, the simulated values are 20 mA, 10 mA, and 0 mA.
 You might be prompted to first input an unlock code.

7.10.4. Simulation of the pulse outputs



This simulation can be used for checking a cable connection or a counting instrument or even a connected controller. According to the output mode, the number of pulses to be simulated is shown in display lines 6 and 7. The simulation is started by the key **++** and a bargraph is displayed. The simulation is finished when the bargraph is completely filled. Then the bargraph is erased.
 You might be prompted to first input an unlock code.

7.10.5. Simulation of the flow rate



This function can simulate the complete metrological functionality of the VOLUMTEC converter, i.e. the pulse outputs and the current output behave like in the normal operation. This function is suitable for the “dry” commissioning of a system or of system sections.

The **++** key starts the function. The flow reads 0 l/h. Each additional activation of the **++** key increases the flow in steps of 10% of Q_{max}. The function stops running after the maximum value is reached.

You might be prompted to first input an unlock code.

7.11. Image level: Info

The image level consists of the pictures BE9, BE9S1, BE9S2.

This image level shows some general information which e.g. serves for the identification of the device.

7.11.1. Info1



The Info1 image shows the software versions and the date of the recent software download.

7.11.2. Info2



The Info2 image shows the hardware version and the board number of the main board.

7.11.3. Info3



The image Info3 shows whether the device is equipped with a SENSORBOX or a MEMBOX. That box includes the stored parameters of the transmitter and customer-specific settings. In case of an exchange of the converter, the parameters will be transmitted with this box to the new converter.

Unless the device is equipped with a parameter box, the text “no parameter box” will be displayed.

If the text “SENSORBOX” is displayed, the new box is available particularly for the VOLUMTEC. If the text “MEMBOX” is displayed, the box included in the converter has been taken over from the previous device, type IZMS.

8. Parameterization

At the factory the VOLUMTEC is provided with standard parameters (factory settings).



Important information

Only trained persons authorized by the user of the flow meter are allowed to set and/or change parameters. The persons concerned have to be familiar with the process sequence. They have to be able to recognize possible risks and to take the necessary steps to eliminate dangers of accident.

Take into account that interventions into the parameters of the flow meter carried out while the production is running could lead to undefined reactions!

It is possible to modify the set parameters via the keypad and the display unit in principle.

The following table shows the functions of the different switch positions:

Parameters	Factory settings	Minimum value	Maximum value
CS3Bus address	32	32	64
Profibus address	5	0	255
Pulse mode	Output mode1	Refer to:	Pulse mode
PV1	1.0	0.0	Depending on output mode, dimension and Qmax
TP1	125 ms	0 ms	16000 ms
PV2	Depending on the nominal width	0.0	Depending on dimension and Qmax
TP2	125 ms	0 ms	16000 ms
Digital input mode	No function		
IT1	125 ms	0 ms	32000 ms
Current output mode	4 – 20 mA active	Refer to:	Current output mode
Qmax 100% for 20mA	Depending on the nominal width	1.0	999999.0
Q type	l/h	l/min	l/h
TP3	0.2 s	0.0 s	30.0 s
LFS = Low Flow Suppression	1.0 %	0.0 %	10.0 %
MSPE	1.0	-1000.0	+1000.0
BSPE	0.0	-1.0	+1.0
Average	32	1	128
Offset	See nameplate	-1.0	+1.0
SPAN	See nameplate	0.000001	1000.0
Pipe detect	Pipe detect	No pipe detect	Pipe detect

DN	Q max [l / h]	PV2 [pulse / l]
10	3000.0	1000.0
15	7000.0	100.0
25	18000.0	100.0
32	30000.0	10.0
40	45000.0	10.0
50	70000.0	10.0
65	120000.0	0.1
80	180000.0	0.01
100	280000.0	0.01
125	440000.0	0.001
150	640000.0	0.001

Table of the abbreviations used and their meaning:

Abbreviation	Function
IMP1	Pulse output 1
IMP2	Pulse output 2
IMP3	Pulse output 3
IN1	Digital input 1
PV1	Pulse value for IMP1
TP1	Pulse length for IMP1
PV2	Pulse value for IMP2
TP2	Pulse length for IMP2
IT1	Pulse length for IN1
Q max.	100% of the flow value for the current output
Q type	Setting of the flow unit
TP3	Time constant for the current output
Dimension	Unit of the volume
LFS	Low-flow suppression
MSPE	Calibration factor
BSPE	Calibration offset
Average	Filter of the flow signal (averaging)
Offset	Calibration value of the transmitter (Do not change!)
SPAN	Calibration value of the transmitter (Do not change!)
Pipe-Detect	Internal EMPTY pipe detection

8.1. Adjustments

The VOLUMTEC normally needs no adjustment.

Usually, the zero point adjustment (“**ZERO adjust**”) is carried out during the first commissioning only.

If, however, some deviations have to be compensated which were determined e.g. upon a comparison with a calibration vessel or a balance it is possible to make an adjustment via the factor “**m spe**”.

However, before you will start carrying out an adjustment you should have clarified the following questions in any rate:

- Are you sure that the reference standard (reference meter, balance, or calibrated vessel) does really deliver an exactly comparative value?
- Is the limitation of quantities always equal from measurement to measurement?
Take into account that differently emptying pipelines, a missing break-off edge for the liquid or temporary air occlusions will lead to faulty results during the measurement!
- Have the production paths been unlocked? Or are there any manual valves or sampling valves or any cross links possibly open?
- Is the liquid really conveyed during the measurement without any air or gas?
- Are the flow limits kept?
- Is the conductivity of the product within the required tolerance?

An adjustment is only reasonable if similar (reproducible) deviations have been ascertained during the comparative measurements.

8.1.1. Adjustment by calibration factor "m spe"

The adjustment by the calibration factor “**m spe**” can be set via the operating unit.

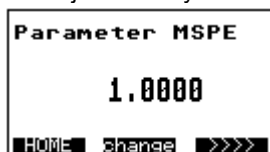

The standard value is set to 1.

The calibration factor is calculated by means of the following formula:

$$V_{ref} \rightarrow \text{Target volume (e.g. calibration vessel, balance, or the like)}$$

$$V_{dis} \rightarrow \text{VOLUMTEC display}$$

Example:

Deviation ΔF of +0.54% determined during a comparative measurement

Calibration vessel: $V_{ref} = 5000 \text{ L}$
 Display: $V_{dis} = 5027 \text{ L}$

$$m_{spe} = \frac{5000}{5027} \cdot 1.0 = \underline{0.9946}$$

8.2. Measuring accuracy:

$\pm 0.2 \% \pm 1 \text{ mm/s}$ under reference conditions

Reference conditions for the determination of the measuring accuracy according to DIN EN 29104 and VDI/VDE 2641:

- Temperature of the measured product: $+28^{\circ}\text{C} \pm 2 \text{ K}$
- Ambient temperature: $+22^{\circ}\text{C} \pm 2 \text{ K}$
- Warm-up period: 30 minutes

Installation:

- Inlet pipe section $> 10 \times \text{DN}$
- Outlet pipe section $> 5 \times \text{DN}$
- Transmitter and converter are earthed/grounded.
- The transmitter is positioned in the centre of the pipeline.

9. Troubleshooting

9.1. Error diagnosis

The VOLUMTEC is equipped with an integrated self-monitoring function. Malfunctions are recognized and automatically removed, if necessary.

9.1.1. Error diagnosis via the display

Displayed messages can support the troubleshooting in case of malfunction or faulty measurement. A distinction is made between error messages for the measurement or for the operating system. The messages are displayed on the service level:



Error message for the measurement

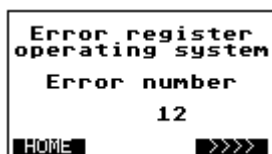

Error message for the operating system

Usually, all displayed messages are erased when the volume is reset to zero. In case of a permanent malfunction, however, the message will be reactivated over and over again.

9.1.2. Error list

Error No.:	Diagnosis	Remedial actions
901	Measurement is continued after an interruption due to: - Voltage drop (POWER-FAIL) - Parameter change - Activation of the digital input "IN1"	None
903	Signal overflow within the electronic unit due to: - Too high flow rate (> 12 m/s) - Electrical influences that can occur in case of an empty meter tube - Defective electronics	a. Check the flow rate! b. If the meter tube is empty, a check will be possible with short-circuited electrodes only.
905	Error found on the occasion of the internal examination of the quantity registers	a. The measuring result can be falsified due to the interference received. - Reset the message by resetting the individual quantity to zero! b. Check the whole installation for possible EMC interference sources; frequency converters have to be laid into separate cable channels! - Ensure good shieldings and earthings/groundings for all devices! - Use the compact device version for critical installations!
922	Reference voltage is missing	Replace the converter!
924	Reference voltage is outside the tolerance	Replace the converter!
928	Coil current is outside the tolerance	Replace the converter!
932	No coil current is available	Check the connection of the transmitter!
963	Pulse output of the output channel IMP1 is exceeded.	- Adapt the flow rate! - Reduce the pulse value " pv1 "!
964	Pulse output of the output channel IMP2 is exceeded.	- Adapt the flow rate! - Reduce the pulse value " pv2 "!
3031	Parameters of the transmitter cannot be saved.	Replace the converter!
3034	The calibration parameters of the electronics are faulty.	Replace the converter!
3035	Free parameters are faulty.	Replace the converter!
3036	Parameters of the transmitter are defective: Checksum error.	Replace the converter!
3037	Base parameters for the measurement are faulty: Checksum error.	Replace the converter!
3052	Meter parameters are faulty: Checksum error.	Replace the converter!
3063	Pulse value " pv1 " set for the counting output IMP1 is too high (>1000 Hz).	Reduce the pulse value " pv1 "!
3064	Pulse value " pv2 " set for the counting output IMP2 is too high (>1000 Hz).	Reduce the pulse value " pv2 "!
3070	One of the calibration factors is set to zero.	Input the respective factor (e.g. SPAN)!
3083	The "ZERO adjust" measurement has not been accepted.	During the adjustment the flow rate was not "zero".

9.2. Typical effects or error sources

Disturbances or malfunctions can normally be recognized by the aid of the display unit only.

9.2.1. Flow without flow rate indication:

- Is the conductivity higher than 5 $\mu\text{S}/\text{cm}$? Is the conductivity higher than 20 $\mu\text{S}/\text{cm}$ in case of demineralised water?
- Has the internal **EMPTY pipe detection** to be switched off?
Check whether the display shows "0 L/h" while the flow is running!
If "adsum 0" is displayed, the internal EMPTY pipe detection is active! This is the case, when:
 - The conductivity of the liquid is below 50 $\mu\text{S}/\text{cm}$.
 - The type of transmitter connected is smaller than DN 15.
 - A heavily pulsating flow is available.

To make sure that the electronic part is working correctly, use the existing simulating function (hardware or software) for your further diagnosis of the digital or analog output!

9.2.2. No pulse transmission despite displayed flow

- (a) Check the electric circuit (the VOLUMTEC outputs have to be supplied by an auxiliary voltage of 24 V DC)!
- (b) Is the polarity of the pulse counter correctly connected?
- (c) Check the parameters:
 - Is the pulse value too low? (Parameter setting)

Use the simulating function for your further diagnosis (hardware or software)!

9.2.3. No analog signal available

If no analog signal or a faulty analog signal is measured, the following checks are recommended to be carried out:

- a. First the connected measuring system (digital display, PLC or the like) has to be completely disconnected from the VOLUMTEC. The analog output signal has to be checked by the simulating function by the aid of an ammeter:
 - If the analog output is ZERO at a 50% simulation, the electronic part is defective, i.e. it will be necessary to replace the complete converter.
 - If the analog output remains constant at 20 mA, the internal "current mode" parameter could be wrong. Verification is possible by means of the operating unit.
- b. If the differences only occur after the disconnection of the external evaluating device, it should be checked:
 - If the burden of the whole current loop is higher than 500 Ω ? (Observe the technical data sheets of the connected devices!)
 - If the input of the external evaluating device is erroneously designed as an "active" analog output?
Faults can especially occur upon a connection to a PLC due to the fact that it might both have an "active" and a "passive" configuration.
- c. If nonlinearities occur over the whole range from 0 - 100%, it should be checked:
 - Whether the burden of the whole current loop is higher than 500 Ω ?

9.2.4. Deviations of measured values

- a) Is there a time-related connection between the occurrence of the problem and some modifications to a system in the vicinity of the measuring device?
- b) Does the deviation show more or less similar values or a constant shift or does it heavily scatter into the positive or negative direction?
- c) Has something been repaired or replaced?
- d) Does the deviation always occur at a certain point of time (e.g. on Mondays at the start of production, on the early shift, or the like) or at certain process steps?
- e) If a display unit is connected, the measuring signals can be checked by means of the service data while the flow is static.
 - Change the display to the presentation of the measured values "adksum" which may be fluctuating between -300 ... +300 units at a maximum.
 - If you carry out several zero point measurements ("ZERO adjust"):
The displayed value is not allowed to change by more than 10 units among the repeated measurements.

Unless stability exists, the earthing/grounding of the transmitter will have to be checked. The wiring between transmitter and converter has to be shielded through the metal cable gland.
- f) The same verification has to be carried out with a full meter tube while the transmitter is removed as a whole. Any interfering influences by electrical disturbances or a leaking pipe system can be excluded in that status.
- g) In case of moisture or other faults in the transmitter or converter it will be necessary to replace the measuring instrument by a new one.
- h) Check the pipe path for by-pass lines or air occlusions (faulty seals).

- i) Check the reference measuring methods or the test procedure (reference meter such as a balance):
- Take into account the temperature compensation of the volume.
 - If different products are compared with the value of the balance, the conversion will have to be carried out by means of the density.
- Or the same volume differences always occur e.g. at different quantities!
If so, possible reasons could be:
- A start and stop of the measurement while the meter tube is empty.
 - An undefined limitation of quantity due to the absence of a break-off edge.
 - An undefined dropping-off behaviour due to the absence of an appropriate draining sieve.
- j) Low conductivities or pulsating flow upon the use of the internal **EMPTY pipe detection**.

9.3. Error reset

Error messages can be reset:

- (a) By a zero reset of the quantity counter
(b) Automatically after a maximum period of 30 seconds, unless any further fault did occur.

9.4. Transmitter tests

9.4.1. Insulation test

The test is carried out by means of an ohmmeter. The meter tube of the transmitter has to be completely emptied before. The inner tube has to be absolutely dry, especially for measurements a) and b).

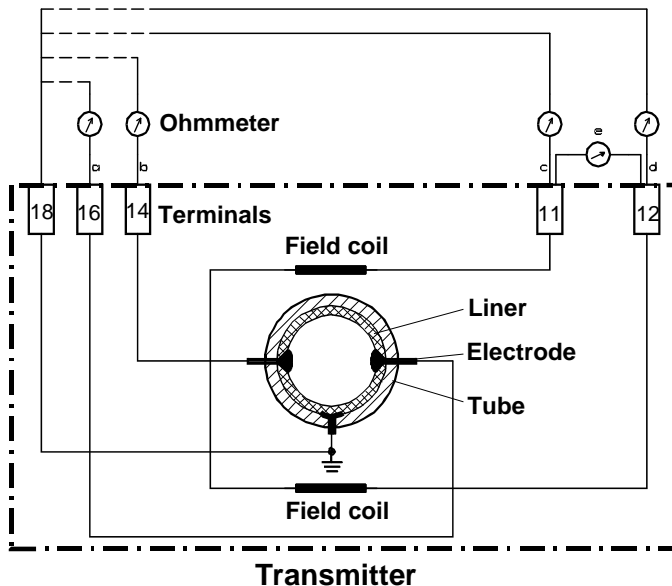

Figure: Insulation test

9.4.2. Visual check

The transmitter can be optically checked while being disassembled:

	Ohmmeter to terminal	Required resistance
a	14 / 18	> 20 megohms
b	16 / 18	> 20 megohms
c	11 / 18	> 20 megohms
d	12 / 18	> 20 megohms
e	11 / 12	70 ... 120 ohms

Reason	Action
Humidity in the connection housing	Dry the housing and perform an insulation test subsequently!
Damaged PFA liner	Replace the transmitter; check the seal!

Table: Visual check

10. Maintenance

10.1. Safety instructions for maintenance work

Maintenance and repair work must only be carried out by skilled and accordingly trained personnel entrusted with the required authorization from the user. The persons concerned have to be familiar with the process sequence and be able to recognize possible dangers and to take all necessary steps to remove imminent risks of accidents.



Caution

First ensure your personal safety before you will start carrying out any service and maintenance work!

- Appropriate measures have to be taken to guarantee a safe stability (approved ladders, lifting platforms, safety harnesses, etc.).
- Applicable tools and personal protective measures are necessary.
- Before you start working at electrical or rotating equipment, make absolutely sure that the equipment concerned is disconnected from the power supply network! An unintended restart has to be avoided by suitable safety precautions (e.g. information signs or padlocks).
- Fittings and instruments and their contents can be hot! First permit them to cool down before you will start working at such parts!
- If fittings and instruments have to be removed from the pipe system, the whole pipe system has to be completely emptied, depressurized, and protected by some appropriate shut-off fittings.
- Rinse the pipe system with clear water before the disassembly of fittings or instruments in order to remove possible residuals of chemicals!

10.2. Routine maintenance

On normal operating conditions the flow meter type VOLUMTEC does not require any special maintenance work.

Nevertheless, we wish to give you some recommendations for maintenance steps:

Cleaning

Deposits in the meter tube or at the electrodes will cause measuring errors or malfunctions.

Thus, ensure a regular and careful cleaning of both the pipelines and the flow meter!

See to it during the external cleaning that e.g. no high-pressure steam-jets are directed to the housing parts!

In case of flow meters with integrated display the external cleaning temperature must not exceed 50 °C.

The pane of the operating unit should only be cleaned by means of clear water and a soft cloth.

The VOLUMTEC transmitter is suitable for CIP in principle.

Regarding the cleaning, disinfecting, and flushing agents and procedures we refer to the manufacturers and the relevant guidelines of the food processing industry.

Seals

The process seal has to be replaced from time to time.

Accuracy Test

Accuracy tests of the flow meter should be carried out in the frame of your in-house quality assurance.

A regular calibration by the Service Engineers of Hengesbach increases the reliability of the measuring instrument.

10.2.1. Preventive maintenance steps

A regular and careful maintenance of the measuring spot (flow meter in its fitting situation) is indispensable in order:

- To avert any danger for persons and the environment
- Not to endanger the product quality
- Not to reduce the service life of the system and its components

The preventive maintenance steps for the flow meter type VOLUMTEC refer to the **seals of the pipe connections**.

The recommended maintenance intervals result from the experience in other systems. However, the really required maintenance intervals can considerably differ from that experience for the following reasons:

- Daily running time and number of the annual production days
- Aggressiveness of the media
- Frequency of cleaning phases, especially with hot water and caustic solution as well as disinfectants
- Duration and temperature of the cleaning phases
- Possible beginning to dry of product residuals

Hengesbach recommends checking the measuring spot continuously, i.e.:

The **operators** of the system should **currently** pay attention to:

- occurring leaks
- unusual measuring results

Regular maintenance:

Following different strategies suggest themselves:

1. A consequent replacement of **all** seals and wearing parts in regular intervals, e.g. every year. Exceptions have to be allowed as a matter of course.
2. Replacement of heavier stressed seals and wearing parts in short intervals (e.g. once a year) and of less stressed parts in larger intervals (e.g. every 2 years). It is important that the serviced components are marked accordingly.
3. Exchange of the seals and wearing parts when required (e.g. when leaks occur). On that occasion it is reasonable to replace the wearing parts in the whole adjoining area, especially of the strongly stressed parts. It is indispensable to mark the serviced components accordingly.
4. Accuracy tests of the measuring instruments of the system in regular intervals in the frame of the in-house quality assurance. Moreover, the measuring instruments should be regularly calibrated at the manufacturer's workshop.

Of course, the aforesaid regular maintenance work can be carried out by the specialists of our service department, if preferred. If so, the desired date should be co-ordinated in good time, in order to combine any predictable production pauses of the system with the schedule of our service staff.

Phone No.: +49 (0)2104 / 30 32 - 0

10.3. Repairs

10.3.1. Sending-in the flow meter to the manufacturer

If repairs have to be carried out at the factory, the following conditions will have to be fulfilled in order to enable a quick and cost-effective settlement.

- The components/devices have to be packed in such a way that damage in transit is excluded.
- The forms "**Fault Location Report**" and "**Declaration of Product Safety**" which you will find in the appendix of this instruction manual have to be completed and added to the delivery of the components/devices to be repaired.
- Without those form the handling of the repairs could be delayed by superfluous queries.

10.3.2. Repair Work

Repairs are allowed to be carried out by skilled and accordingly trained personnel only. Interventions in the electronic boards are impossible. Only complete converters can be exchanged.

For each repair it is indispensable to strictly observe the general maintenance safety instructions.

A replacement of components in the fitting position should be avoided for the following reasons:

- Lock washers could drop out and be left on the electronic part when the fastening screws are loosened.
- Metal particles could destroy the electronic part when the power supply is switched on.
- When the electronic housing is open there is the risk that moisture could drip down onto the electronic boards. Moisture immediately destroys the electronic part when the power supply is switched on.

For all kinds of repairs the flow meter has to be definitely separated from the power supply!

10.3.2.1. Replacement of the sealing cover of the operating unit

The sealing cover will have to be replaced if the front pane is destroyed or scratched and if the operating unit does not function.

10.3.2.2. Replacement of the transmitter

Before replacing the transmitter, ensure that the pipe system is empty and unpressurized!
Flush the pipe system before the removal of the transmitter with clear cold water in order to avoid any residues of chemicals or elevated temperatures.
The distribution voltage for the electronic part has to be switched off.
Carry out a zero point measurement ("ZERO adjust") with the new transmitter in order to optimize the accuracy of the flow meter!

10.4. Special program functions

The program of the VOLUMTEC offers some functions that could support a troubleshooting process. Moreover, it is possible to use those functions for the adjustment and verification of connected devices.

10.4.1. Flow simulation

As an adjusting aid or for diagnosing purposes of connected devices the VOLUMTEC offers the possibility to simulate flow without any flowing product.

10.4.2. Simulation via the display unit

Select the "SIMULATION" function by means of the keypad.

During the simulation the analog output is set to 12.0 mA (4...20 mA setting) or 10.0 mA (0...20mA setting). The volume pulses are produced for the flow of 50 % according to the set pulse value.

10.5. Spare parts to be kept available on stock

The spare parts list results from the experience in the different applications of the flow meter. However, the actually required spare parts may be deviating from it for the following reasons:

- Daily running time and number of the annual production days
- Aggressiveness of the media
- Frequency of the required cleaning phases, especially with hot water, caustic solution, and disinfectants
- Duration and temperature of the cleaning phases

The following details are absolutely necessary and should never be missing in a spare parts order:

- Quantity and unit
- Designation
- Hengesbach stock/order number

The appendix of this instruction manual includes some lists of wearing parts or spare parts.

11. Decommissioning

11.1. Temporary decommissioning

Should the device be put out of operation for a temporary period only, no special measures have to be observed for its later recommissioning.

If the transmitter is removed out of the process line, the pipe system first has to be emptied and depressurized.

Before removing the transmitter flush the pipe system with clear cold water in order to avoid any residues of chemicals or elevated temperatures.

Attach the covers for the protection of the liner.

11.2. Final decommissioning / disposal

If the whole device is defective beyond repair, you should take into account for the final decommissioning that wastes, contrivances, and system components to be scraped will have to be disposed of according to the valid laws, decrees, and regulations for waste disposal.

12. Technical Data

General information	
Device type	VOLUMTEC magnetic-inductive flow-measuring device for liquid media
Input	
Flow range	30l/h ... 640m ³ /h (depending on the nominal diameter)
Pressure range	0.1 ... 11bar abs. (PN 10)
Control input	3...32V DC, R _i < 3,2 kΩ
Output	
Flow output	0/4...20mA, active or passive, load max. 500Ω
Impulse output (volume)	2x opto-coupler, 24 V / 20mA, max. 1000Hz
Status output	Opto-coupler, ready, fault, direction
Measuring accuracy	
Typical accuracy	± 0.20% FS
Conditions for use	
Medium temperature	Compact: 0...100°C permanent temperature, 130°C max. for 30 minutes Separate: 0...120°C permanent temperature
Environmental temperature	-25 ... + 55°C
Storage temperature	-25 ... + 55°C
Minimum conductivity medium	Compact version ≥ 5μS/cm Separate version ≥ 15μS/cm, or see connection cable
Upstream	≥ 5 x DN
Downstream	≥ 3 x DN
Protection class EN 60529	IP67, standard
Grounding resistance	< 10Ω
Electromagnetic compatibility	according to EMC Directive 2004/108/EC
Design configuration	
Process connection	modular connection system with aseptic collar flange according to DIN11864-2 Form A
Process connection adapter	welded necks for pipes according to DIN 11850, threaded necks and conical connections with grooved union nut according to DIN11851, clamp, etc.
Materials for compact and separate version	housing: 304 in contact with product: Electrodes 316L PFA measuring pipe lining (FDA) seal: on process side: EPDM (FDA)
Surface roughness	housing R _a ≤ 2.5μm measuring pipe lining R _a ≤ 0.8μm
Nominal diameter	DN10 ... DN150
electrical connection	3x cable clamp M16x1,5
Connection cable for separate version	shielded cable: 2x0,5mm ² F-CYOZ, 4x0,5mm ² LIYCY-0
Display	graphics LCD display 46 x 23 mm, illuminated
Longer connection cable for separate version	
max. 5m	conductivity from 15-50μs/cm
max. 20m	conductivity from 50-200μs/cm
max. 50m	conductivity from > 200μs/cm
Auxiliary energy	
Supply voltage	DC version: 9...32V DC AC version: 100...240V AC, 50...60 Hz
Power input	7W
Configuration interfaces	
Interface	CS3-BUS / RS485
Fieldbus	PROFIBUS DP
Radio connection	Bluetooth  Class 2

13. Dimensional drawings

(without process-connection adapters)

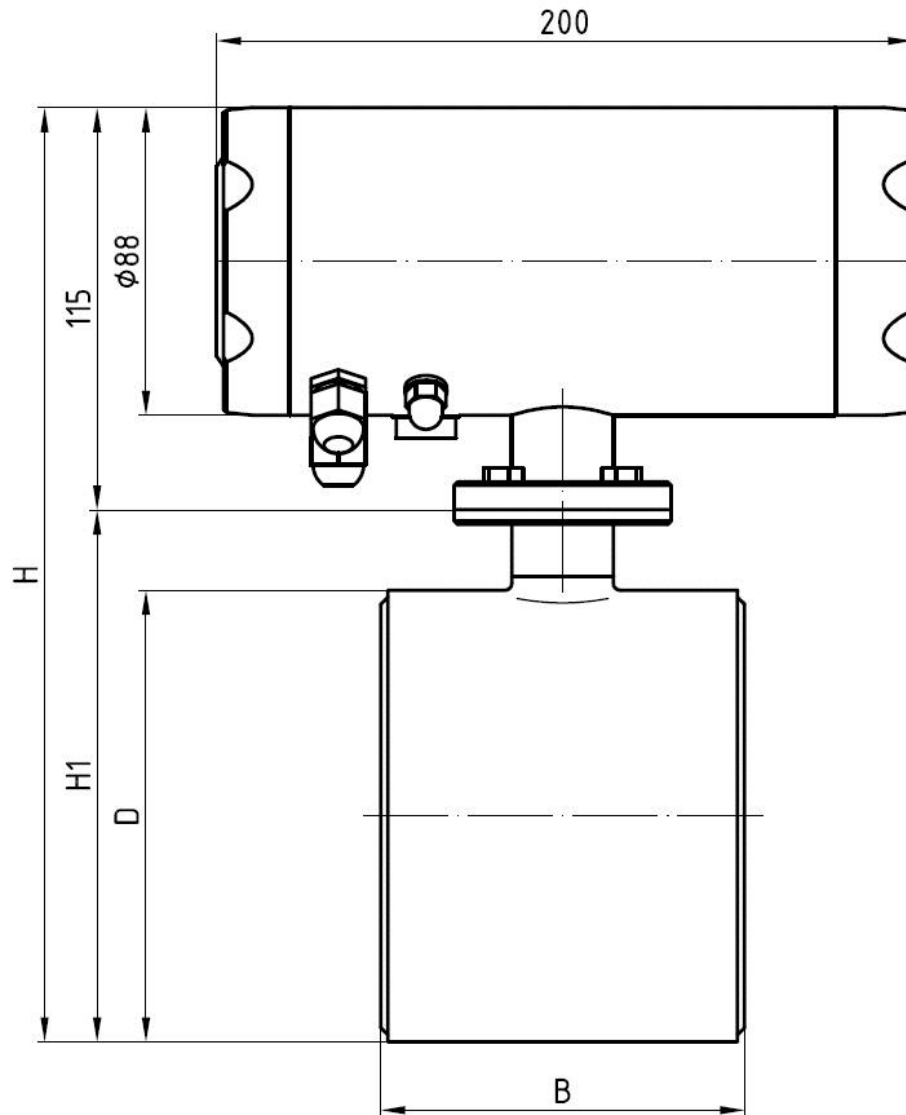

nominal width	B [mm]	H [mm]	D [mm]	H1 [mm]	flow rate [L/h]	weight [kg]
						compact version
DN 10	104	225	90	110	30...3.000	6
DN 15	104	225	90	110	70...7.000	6
DN 25	104	225	90	110	180...18.000	6
DN 32	104	240	105	125	300...30.000	7
DN 40	104	240	105	125	450...45.000	7
DN 50	104	265	130	150	700...70.000	8
DN 65	104	265	130	150	1.200...120.000	8
DN 80	105	290	155	175	1.800...180.000	12
DN 100	110	305	170	190	2.800...280.000	17
DN 125	110	355	220	240	4.400...440.000	22
DN 150	140	355	220	240	6.400...640.000	25

Dimensional drawings

separated-version transmitter
 (without process-connection adapters)

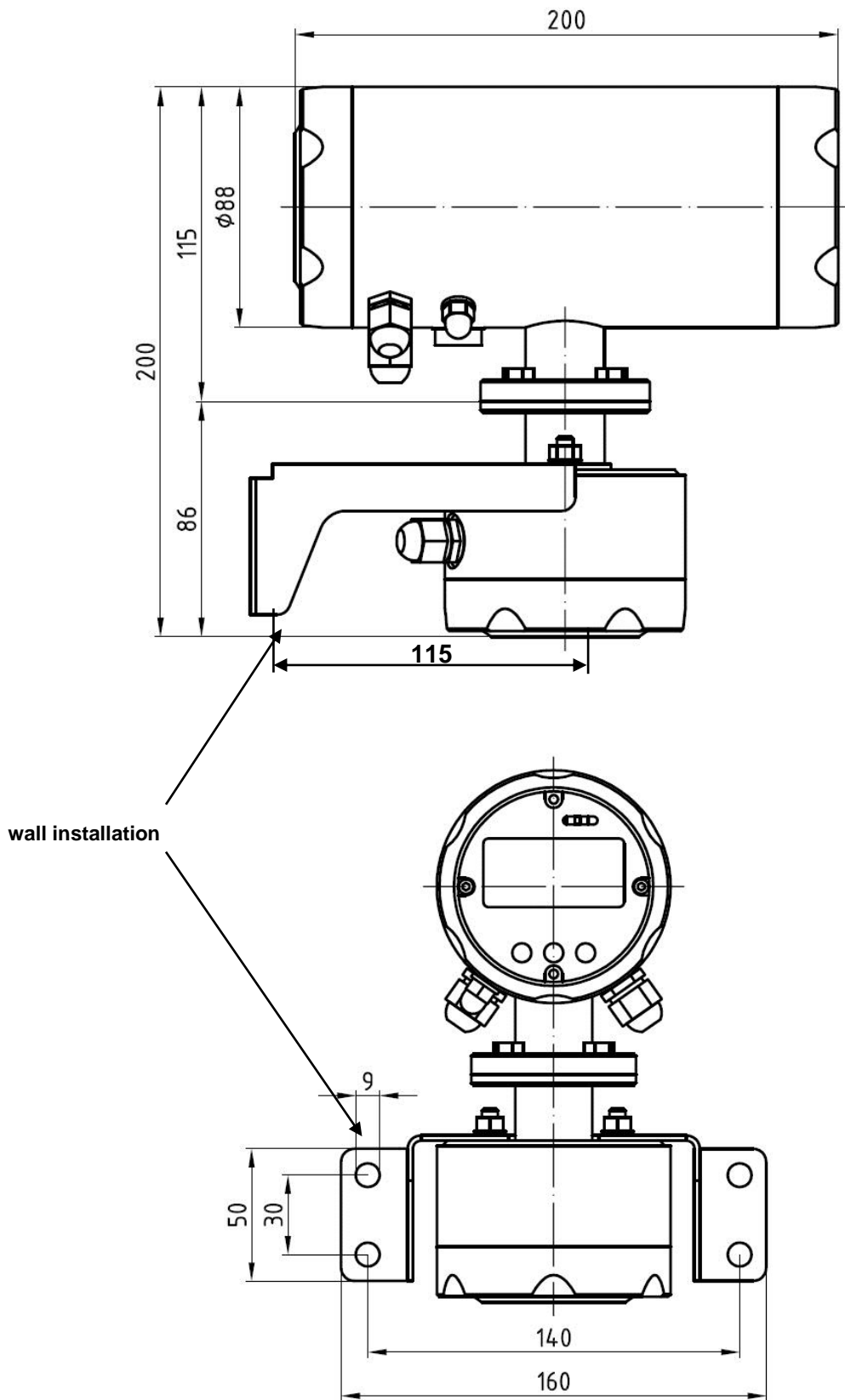

Dimensional drawings

separated-version sensor
(without process-connection adapters)

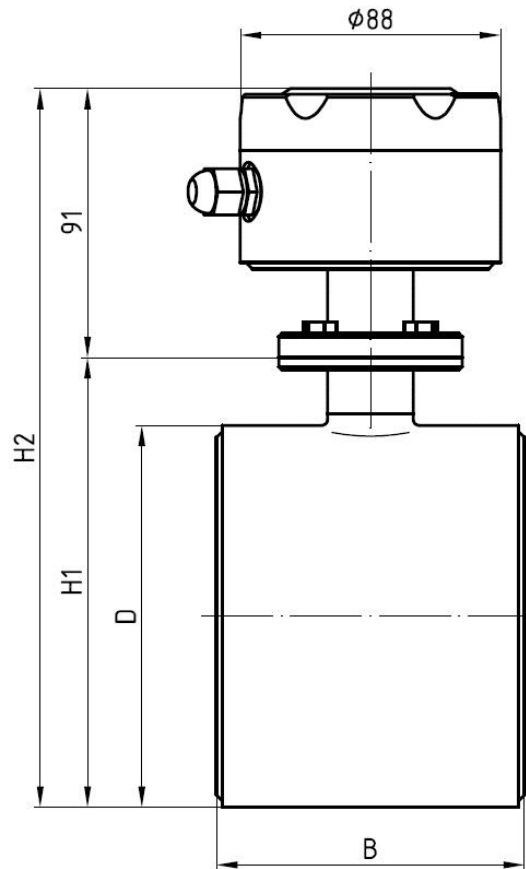

nominal width	B [mm]	D [mm]	H1 [mm]	H2 [mm]	flow rate [L/h]	weight [kg]	
						separated version	transmitter
DN 10	104	90	110	201	30...3.000	4	5
DN 15	104	90	110	201	70...7.000	4	5
DN 25	104	90	110	201	180...18.000	4	5
DN 32	104	105	125	216	300...30.000	5	5
DN 40	104	105	125	216	450...45.000	5	5
DN 50	104	130	150	241	700...70.000	6	5
DN 65	104	130	150	241	1.200...120.000	6	5
DN 80	105	155	175	266	1.800...180.000	10	5
DN 100	110	170	190	281	2.800...280.000	15	5
DN 125	110	220	240	331	4.400...440.000	20	5
DN150	140	220	240	331	6.400...640.000	23	5

Dimensional drawings

welding adapters for pipes according to DIN 11850

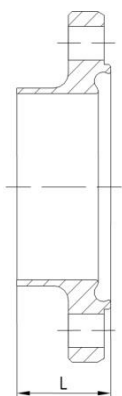

nominal width	L [mm]
DN10	25,5
DN15	25,5
DN25	25,5
DN32	25,5
DN40	25,5
DN50	25,5
DN65	25,5
DN80	27,5
DN100	27,5
DN125	29,5
DN150	29,5

Clamp according to DIN 32676

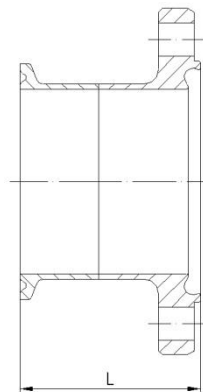

nominal width	L [mm]
DN10	49,5
DN15	49,5
DN25	49,5
DN32	49,5
DN40	49,5
DN50	49,5
DN65	49,5
DN80	49,0
DN100	71,5
DN125	56,5
DN150	56,5

threaded socket according to DIN 11851

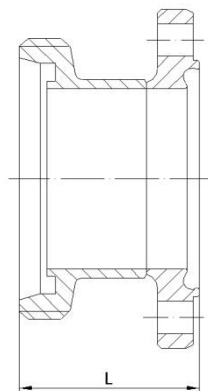

nominal width	L [mm]
DN10	49,5
DN15	49,5
DN25	49,5
DN32	49,5
DN40	49,5
DN50	49,5
DN65	49,5
DN80	49,0
DN100	71,5
DN125	56,5
DN150	56,5

conical socket with groove nut according to DIN

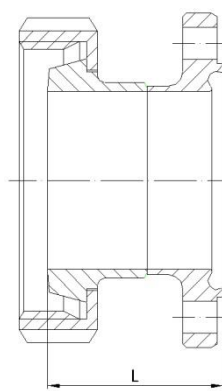

nominal width	L [mm]
DN10	49,5
DN15	49,5
DN25	49,5
DN32	49,5
DN40	49,5
DN50	49,5
DN65	49,5
DN80	49,0
DN100	71,5
DN125	56,5
DN150	56,5

DIN flange EN ISO 1092-1

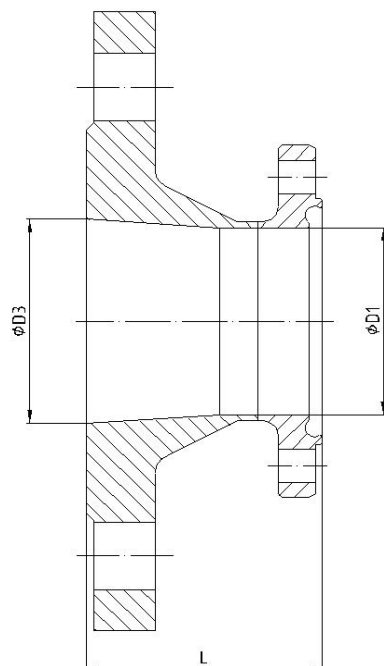

nominal width	L [mm]
DN10	49,5
DN15	49,5
DN25	49,5
DN32	49,5
DN40	49,5
DN50	49,5
DN65	49,5
DN80	49,0
DN100	71,5
DN125	56,5
DN150	56,5

threaded holes device side

nominal width	quantity	thread width
DN10	4	M8
DN15	4	M8
DN25	4	M8
DN32	4	M8
DN40	4	M8
DN50	4	M8
DN65	8	M8
DN80	8	M10
DN100	8	M10
DN125	8	M10
DN150	8	M12

All non-dimensioned sizes are per
DIN EN 1092-1
PN16, type 11, Form B (DN10-100)
PN10, type 11, Form B (DN125-150)

* further dimensional drawings on request

F-TI-VOLUMTEC-B-en-13-1/55

14. Ordering information

Version

K	compact-version: sensor and transmitter are directly connected
G	separated: connection between sensor and transmitter via cable, 5m (standard)

Auxiliary supply

DC	9...32 V DC
AC	100...240 V AC, 50...60 Hz

Elektronics

0	Standard
1	PROFIBUS DP

Nominal width

B	DN 10 PN 10
C	DN 15 PN 10
D	DN 25 PN 10
E	DN 32 PN 10
F	DN 40 PN 10
G	DN 50 PN 10
H	DN 65 PN 10
I	DN 80 PN 10
K	DN 100 PN 10
L	DN 125 PN 10
M	DN 150 PN 10

VOLUMTE

Process connection adapters *

Process connection adapter

FES	welding adapters for pipes according to DIN 11850
FAF	FG hygiene flange
FMN	conical socket with groove nut according to DIN 11851
FMG	threaded socket according to DIN 11851
FCL	Clamp according to DIN 32676
FVA	VARIVENT [®] flange
FFB	flange PN10 DIN EN 1092-1, type 11, form B
FS9	other process-connection adapter

Nominal width

B	DN10 PN10
C	DN15 PN10
D	DN25 PN10
E	DN32 PN10
F	DN40 PN10
G	DN50 PN10
H	DN65 PN10
I	DN80 PN10
K	DN100 PN10
L	DN125 PN10
M	DN150 PN10

FVLT

* customer-specific process connection adapter for existing applications on request

15. Contact details

Do you have any further questions or wishes left?
Of course, we are readily prepared to assist you.

Our company's address is:

Hengesbach GmbH & Co. KG
Schimmelbusch Straße 17
40699 Erkrath
Germany

You can reach our **central service department** under:

Phone no.: +49 21 04 / 30 32 - 0
Fax no.: +49 21 04 / 30 32 - 22
E-mail address: info@hengesbach.com

Our service department will help you to quickly find the best suitable specialist for your questions.

This instruction manual is not subject to an updating service by **Hengesbach GmbH & Co. KG**.

Modifications to this instruction manual and all rights reserved.